

Solutions Manual for  
**Fluid Mechanics: Fundamentals and Applications**  
Third Edition  
Yunus A. Çengel & John M. Cimbala  
McGraw-Hill, 2013

---

**CHAPTER 6**  
**MOMENTUM ANALYSIS OF FLOW**  
**SYSTEMS**

---

PROPRIETARY AND CONFIDENTIAL

This Manual is the proprietary property of The McGraw-Hill Companies, Inc. (“McGraw-Hill”) and protected by copyright and other state and federal laws. By opening and using this Manual the user agrees to the following restrictions, and if the recipient does not agree to these restrictions, the Manual should be promptly returned unopened to McGraw-Hill: **This Manual is being provided only to authorized professors and instructors for use in preparing for the classes using the affiliated textbook. No other use or distribution of this Manual is permitted. This Manual may not be sold and may not be distributed to or used by any student or other third party. No part of this Manual may be reproduced, displayed or distributed in any form or by any means, electronic or otherwise, without the prior written permission of McGraw-Hill.**

---

## Newton's Laws and Conservation of Momentum

---

### 6-1C

**Solution** We are to express Newton's three laws.

*Analysis* Newton's first law states that **"a body at rest remains at rest, and a body in motion remains in motion at the same velocity in a straight path when the net force acting on it is zero."** Therefore, a body tends to preserve its state or inertia. Newton's second law states that **"the acceleration of a body is proportional to the net force acting on it and is inversely proportional to its mass."** Newton's third law states **"when a body exerts a force on a second body, the second body exerts an equal and opposite force on the first."**

*Discussion* As we shall see in later chapters, the differential equation of fluid motion is based on Newton's second law.

---

### 6-2C

**Solution** We are to discuss Newton's second law for rotating bodies.

*Analysis* Newton's second law of motion, also called the *angular momentum equation*, is expressed as **"the rate of change of the angular momentum of a body is equal to the net torque acting it."** For a non-rigid body with zero net torque, the angular momentum remains constant, but the **angular velocity changes in accordance with  $I\omega = \text{constant}$**  where  $I$  is the moment of inertia of the body.

*Discussion* Angular momentum is analogous to linear momentum in this way: Linear momentum does not change unless a force acts on it. Angular momentum does not change unless a torque acts on it.

---

### 6-3C

**Solution** We are to discuss if momentum is a vector, and its direction.

*Analysis* Since momentum ( $m\vec{V}$ ) is the product of a vector (velocity) and a scalar (mass), **momentum must be a vector that points in the same direction as the velocity vector.**

*Discussion* In the general case, we must solve three components of the linear momentum equation, since it is a vector equation.

---

## 6-4C

**Solution** We are to discuss the conservation of momentum principle.

**Analysis** The *conservation of momentum principle* is expressed as “**the momentum of a system remains constant when the net force acting on it is zero, and thus the momentum of such systems is conserved**”. The momentum of a body remains constant if the net force acting on it is zero.

**Discussion** Momentum is not conserved in general, because when we apply a force, the momentum changes.

---



---

## Linear Momentum Equation

---

## 6-5C

**Solution** We are to compare the reaction force on two fire hoses.

**Analysis** **The fireman who holds the hose backwards so that the water makes a U-turn before being discharged will experience a greater reaction force.** This is because of the vector nature of the momentum equation. Specifically, the inflow and outflow terms end up with the same sign (they add together) for the case with the U-turn, whereas they have opposite signs (one partially cancels out the other) for the case without the U-turn.

**Discussion** Direction is not an issue with the conservation of mass or energy equations, since they are scalar equations.

---

## 6-6C

**Solution** We are to discuss surface forces in a control volume analysis.

**Analysis** All surface forces arise as **the control volume is isolated from its surroundings for analysis, and the effect of any detached object is accounted for by a force at that location.** We can minimize the number of surface forces exposed by **choosing the control volume (wisely) such that the forces that we are not interested in remain internal, and thus they do not complicate the analysis.** A well-chosen control volume exposes only the forces that are to be determined (such as reaction forces) and a minimum number of other forces.

**Discussion** There are many choices of control volume for a given problem. Although there are not really “wrong” and “right” choices of control volume, there certainly are “wise” and “unwise” choices of control volume.

---

## 6-7C

**Solution** We are to discuss the importance of the RTT, and its relationship to the linear momentum equation.

**Analysis** The relationship between the time rates of change of an extensive property for a system and for a control volume is expressed by the *Reynolds transport theorem* (RTT), which provides the link between the system and control volume concepts. The linear momentum equation is obtained by **setting  $b = \vec{V}$  and thus  $B = m\vec{V}$  in the Reynolds transport theorem.**

**Discussion** Newton's second law applies directly to a system of fixed mass, but we use the RTT to transform from the system formulation to the control volume formulation.

---

## 6-8C

**Solution** We are to discuss the momentum flux correction factor, and its significance.

**Analysis** The *momentum-flux correction factor  $\beta$*  enables us to express the momentum flux in terms of the mass flow rate and mean flow velocity as  $\int_{A_c} \rho \vec{V} (\vec{V} \cdot \vec{n}) dA_c = \beta \dot{m} \vec{V}_{avg}$ . The value of  $\beta$  is unity for uniform flow, such as a jet flow, nearly unity for fully developed turbulent pipe flow (between 1.01 and 1.04), but about 1.3 for fully developed laminar pipe flow. **So it is significant and should be considered in laminar flow;** it is often ignored in turbulent flow.

**Discussion** Even though  $\beta$  is nearly unity for many turbulent flows, it is wise not to ignore it.

---

## 6-9C

**Solution** We are to discuss the momentum equation for steady one-D flow with no external forces.

**Analysis** The momentum equation for steady flow for the case of no external forces is

$$\sum \vec{F} = 0 = \sum_{\text{out}} \beta \dot{m} \vec{V} - \sum_{\text{in}} \beta \dot{m} \vec{V}$$

where the left hand side is the **net force acting on the control volume** (which is zero here), the first term on the right hand side is the **incoming momentum flux**, and the second term on the right is the **outgoing momentum flux** by mass.

**Discussion** This is a special simplified case of the more general momentum equation, since there are no forces. In this case we can say that momentum is conserved.

---

**6-10C**

**Solution** We are to explain why we can usually work with gage pressure rather than absolute pressure.

**Analysis** In the application of the momentum equation, we can disregard the atmospheric pressure and work with gage pressures only since the **atmospheric pressure acts in all directions**, and its effect cancels out in every direction.

**Discussion** In some applications, it is better to use absolute pressure everywhere, but for most practical engineering problems, it is simpler to use gage pressure everywhere, with no loss of accuracy.

---

**6-11C**

**Solution** We are to discuss if the upper limit of a rocket's velocity is limited to  $V$ , its discharge velocity.

**Analysis** **No,  $V$  is not the upper limit to the rocket's ultimate velocity.** Without friction the rocket velocity will continue to increase (i.e., it will continue to accelerate) as more gas is expelled out the nozzle.

**Discussion** This is a simple application of Newton's second law. As long as there is a force acting on the rocket, it will continue to accelerate, regardless of how that force is generated.

---

**6-12C**

**Solution** We are to describe how a helicopter can hover.

**Analysis** A helicopter hovers because **the strong downdraft of air, caused by the overhead propeller blades, manifests a momentum in the air stream.** This momentum must be countered by the helicopter lift force.

**Discussion** In essence, the helicopter stays aloft by pushing down on the air with a net force equal to its weight.

---

**6-13C**

**Solution** We are to discuss the power required for a helicopter to hover at various altitudes.

**Analysis** Since the air density decreases, **it requires more energy for a helicopter to hover at higher altitudes**, because more air must be forced into the downdraft by the helicopter blades to provide the same lift force. Therefore, it takes more power for a helicopter to hover on the top of a high mountain than it does at sea level.

**Discussion** This is consistent with the limiting case – if there were no air, the helicopter would not be able to hover at all. There would be no air to push down.

---

## 6-14C

**Solution** We are to discuss helicopter performance in summer versus winter.

**Analysis** In winter the air is generally colder, and thus denser. Therefore, less air must be driven by the blades to provide the same helicopter lift, requiring less power. **Less energy is required in the winter.**

**Discussion** However, it is also harder for the blades to move through the denser cold air, so there is more torque required of the engine in cold weather.

---

## 6-15C

**Solution** We are to discuss if the force required to hold a plate stationary doubles when the jet velocity doubles.

**Analysis** **No, the force will not double.** In fact, the force required to hold the plate against the horizontal water stream **will increase by a factor of 4** when the velocity is doubled since

$$F = \dot{m}V = (\rho AV)V = \rho AV^2$$

and thus the *force is proportional to the square of the velocity.*

**Discussion** You can think of it this way: Since momentum flux is mass flow rate times velocity, a doubling of the velocity doubles both the mass flow rate *and* the velocity, increasing the momentum flux by a factor of four.

---

## 6-16C

**Solution** We are to describe and discuss body forces and surface forces.

**Analysis** The forces acting on the control volume consist of *body forces* that **act throughout the entire body of the control volume** (such as gravity, electric, and magnetic forces) and *surface forces* that **act on the control surface** (such as the pressure forces and reaction forces at points of contact). The *net force* acting on a control volume is the **sum of all body and surface forces**. Fluid **weight is a body force**, and **pressure is a surface force** (acting per unit area).

**Discussion** In a general fluid flow, the flow is influenced by both body and surface forces.

---

## 6-17C

**Solution** We are to discuss the acceleration of a cart hit by a water jet.

**Analysis** **The acceleration is not be constant since the force is not constant.** The impulse force exerted by the water on the plate is  $F = \dot{m}V = (\rho AV)V = \rho AV^2$ , where  $V$  is the relative velocity between the water and the plate, which is moving. The magnitude of the plate acceleration is thus  $a = F/m$ . But as the plate begins to move,  $V$  decreases, so the acceleration must also decrease.

**Discussion** It is the *relative* velocity of the water jet on the cart that contributes to the cart's acceleration.

---

6-18C

**Solution** We are to discuss the maximum possible velocity of a cart hit by a water jet.

**Analysis** The **maximum possible velocity for the plate is the velocity of the water jet**. As long as the plate is moving slower than the jet, the water exerts a force on the plate, which causes it to accelerate, until terminal jet velocity is reached.

**Discussion** Once the relative velocity is zero, the jet supplies no force to the cart, and thus it cannot accelerate further.

---

## 6-19

**Solution** The velocity distribution for turbulent flow of water in a pipe is considered. The drag force exerted on the pipe by water flow is to be determined.

**Assumptions** 1 The flow is steady and incompressible. 2 The water is discharged to the atmosphere, and thus the gage pressure at the outlet is zero.

**Properties** We take the density of water to be  $1000 \text{ kg/m}^3$ .

**Analysis** Applying x-component of momentum equation,

$$\frac{\partial}{\partial t} \int_{cv} \bar{V} \rho dV + \int_{cs} \bar{V} \rho \bar{V} \bar{n} dA = \sum F_{cv}$$

$$\rho U_{ave} (-U_{ave}) A_1 + \rho \int_0^R u^2 dA = p_1 A_1 - p_2 A_2 - F_D$$

Recalling that  $U_{ave} = 0.816 U_{max}$  for turbulent flow, we write

$$u = \frac{U_{ave}}{0.816} (1 - r/R)^{1/7} = 1.2255 U_{ave} (1 - r/R)^{1/7}$$

Therefore,

$$-\rho U_{ave}^2 A_1 + \rho \int_0^R 1.5 U_{ave}^2 (1 - r/R)^{2/7} 2\pi r dr = (p_1 - p_2) A - F_D$$

$$-\rho U_{ave}^2 A_1 + 3\pi U_{ave}^2 \rho \int_0^R (1 - r/R)^{2/7} r dr = (p_1 - p_2) A - F_D$$

$$\int_0^R (1 - r/R)^{2/7} r dr = R^2 \int_0^1 \left(1 - \frac{r}{R}\right)^{2/7} \frac{r}{R} d\left(\frac{r}{R}\right)$$

Setting  $1 - r/R = v$ , we obtain

$$\int_0^R (1 - r/R)^{2/7} r dr = -R^2 \int_0^1 (v^{2/7} - v^{9/7}) dv = -R^2 \left[ \frac{7}{9} \left(1 - \frac{r}{R}\right)^{9/7} - \frac{7}{16} \left(1 - \frac{r}{R}\right)^{16/7} \right]_0^1$$

Finally we get

$$\int_0^R (1 - r/R)^{2/7} r dr = R^2 \frac{49}{144}$$

Therefore, the momentum equation takes the form

$$-\rho U_{ave}^2 A_1 + 3\pi U_{ave}^2 \rho R^2 \frac{49}{144} = \Delta p A - F_D$$

$$F_D = \Delta p A + \rho U_{ave}^2 A_1 - \rho \pi U_{ave}^2 R^2 \frac{49}{48}$$

$$F_D = 10,000 \times \frac{\pi 0.1^2}{4} + 1000 \times 3^2 \frac{\pi 0.1^2}{4} - 1000 \pi 3^2 \left(\frac{0.1}{2}\right)^2 \frac{49}{48} \approx 77 \text{ N}$$



## 6-20

**Solution** A horizontal water jet is deflected by a stationary cone. The horizontal force needed to hold the cone stationary is to be determined.

**Assumptions** 1 The flow is steady and incompressible. 2 The water is discharged to the atmosphere, and thus the gage pressure at the outlet is zero.

**Properties** We take the density of water to be  $1000 \text{ kg/m}^3$ .

**Analysis**

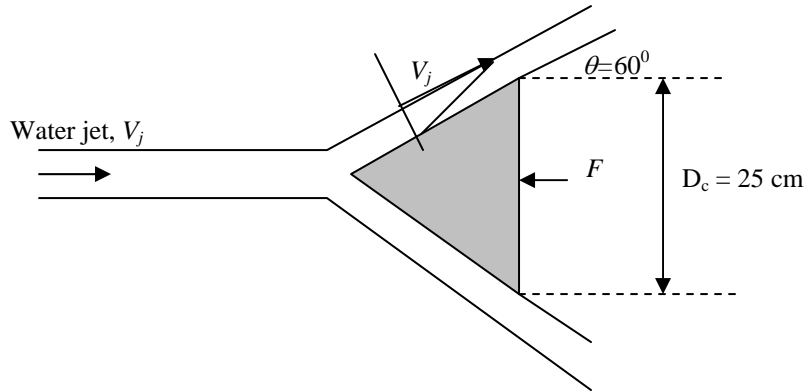

Considering front view of the cone, we apply the conservation of mass,

$$0 = -Q_j + \int_A V_{exit} dA \Rightarrow Q_j \approx \frac{V_j}{2} \pi D_c h$$

$$\frac{\pi}{4} 0.025^2 \times 40 = \frac{40}{2} \pi 0.25 h \Rightarrow h = 1.25 \times 10^{-3} \text{ m} = 1.25 \text{ mm}$$

Linear momentum equation in the x direction gives

$$\int \bar{V} \rho \bar{V} \bar{n} dA = \sum F_x$$

$$-V_j \rho V_j A_1 + \int_0^h (V \cos \theta) \rho V (\pi D_c) dY = -F$$

Since velocity is linear, it is in the form of  $V = a + bY$ . It is given that  $V=0$  when  $Y=0$ , and  $V=V_j$  when  $Y=h=1.25 \times 10^{-3} \text{ m}$ . Therefore we obtain

$$V = 32000Y$$

$$-1000 \times 40^2 \frac{\pi}{4} 0.025^2 + 1000 \times \pi 0.25 \times (\cos 60) \times 32000^2 \int_0^{1.25 \times 10^{-3}} Y^2 dY = -F$$

$$F = -785 + 262 = \mathbf{523 \text{ N}}$$

## 6-21

**Solution** A water jet of velocity  $V$  impinges on a plate moving toward the water jet with velocity  $\frac{1}{2}V$ . The force required to move the plate towards the jet is to be determined in terms of  $F$  acting on the stationary plate.

**Assumptions** **1** The flow is steady and incompressible. **2** The plate is vertical and the jet is normal to plate. **3** The pressure on both sides of the plate is atmospheric pressure (and thus its effect cancels out). **4** Friction during motion is negligible. **5** There is no acceleration of the plate. **6** The water splashes off the sides of the plate in a plane normal to the jet. **6** Jet flow is nearly uniform and thus the effect of the momentum-flux correction factor is negligible,  $\beta \cong 1$ .

**Analysis** We take the plate as the control volume. The relative velocity between the plate and the jet is  $V$  when the plate is stationary, and  $1.5V$  when the plate is moving with a velocity  $\frac{1}{2}V$  towards the plate. Then the momentum equation for steady flow in the horizontal direction reduces to

$$\sum \vec{F} = \sum_{\text{out}} \beta \dot{m} \vec{V} - \sum_{\text{in}} \beta \dot{m} \vec{V} \rightarrow -F_R = -\dot{m}_i V_i \rightarrow F_R = \dot{m}_i V_i$$

*Stationary plate:* ( $V_i = V$  and  $\dot{m}_i = \rho A V_i = \rho A V$ )  $\rightarrow F_R = \rho A V^2 = F$

*Moving plate:* ( $V_i = 1.5V$  and  $\dot{m}_i = \rho A V_i = \rho A (1.5V)$ )

$$\rightarrow F_R = \rho A (1.5V)^2 = 2.25 \rho A V^2 = 2.25 F$$

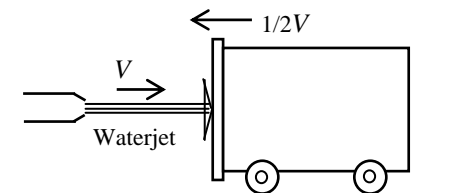

Therefore, the force required to hold the plate stationary against the oncoming water jet becomes **2.25 times greater** when the jet velocity becomes 1.5 times greater.

**Discussion** Note that when the plate is stationary,  $V$  is also the jet velocity. But if the plate moves toward the stream with velocity  $\frac{1}{2}V$ , then the *relative* velocity is  $1.5V$ , and the amount of mass striking the plate (and falling off its sides) per unit time also increases by 50%.

## 6-22

**Solution** A 90° elbow deflects water upwards and discharges it to the atmosphere at a specified rate. The gage pressure at the inlet of the elbow and the anchoring force needed to hold the elbow in place are to be determined.

**Assumptions** 1 The flow is steady and incompressible. 2 Frictional effects are negligible in the calculation of the pressure drop (so that the Bernoulli equation can be used). 3 The weight of the elbow and the water in it is negligible. 4 The water is discharged to the atmosphere, and thus the gage pressure at the outlet is zero. 5 The momentum-flux correction factor for each inlet and outlet is given to be  $\beta = 1.03$ .

**Properties** We take the density of water to be  $1000 \text{ kg/m}^3$ .

**Analysis** (a) We take the elbow as the control volume, and designate the entrance by 1 and the outlet by 2. We also designate the horizontal coordinate by  $x$  (with the direction of flow as being the positive direction) and the vertical coordinate by  $z$ . The continuity equation for this one-inlet one-outlet steady flow system is  $\dot{m}_1 = \dot{m}_2 = \dot{m} = 40 \text{ kg/s}$ . Noting that  $\dot{m} = \rho AV$ , the mean inlet and outlet velocities of water are

$$V_1 = V_2 = V = \frac{\dot{m}}{\rho A} = \frac{\dot{m}}{\rho(\pi D^2/4)} = \frac{40 \text{ kg/s}}{(1000 \text{ kg/m}^3)[\pi(0.1 \text{ m})^2/4]} = 5.093 \text{ m/s}$$

Noting that  $V_1 = V_2$  and  $P_2 = P_{\text{atm}}$ , the Bernoulli equation for a streamline going through the center of the reducing elbow is expressed as

$$\frac{P_1}{\rho g} + \frac{V_1^2}{2g} + z_1 = \frac{P_2}{\rho g} + \frac{V_2^2}{2g} + z_2 \rightarrow P_1 - P_2 = \rho g(z_2 - z_1) \rightarrow P_{1,\text{gage}} = \rho g(z_2 - z_1)$$

Substituting,

$$P_{1,\text{gage}} = (1000 \text{ kg/m}^3)(9.81 \text{ m/s}^2)(0.50 \text{ m}) \left( \frac{1 \text{ kN}}{1000 \text{ kg} \cdot \text{m/s}^2} \right) = 4.905 \text{ kN/m}^2 \cong \mathbf{4.91 \text{ kPa}}$$

(b) The momentum equation for steady flow is  $\sum \vec{F} = \sum_{\text{out}} \beta \dot{m} \vec{V} - \sum_{\text{in}} \beta \dot{m} \vec{V}$ . We let the  $x$ - and  $z$ - components of the anchoring force of the elbow be  $F_{Rx}$  and  $F_{Rz}$ , and assume them to be in the positive directions. We also use gage pressures to avoid dealing with the atmospheric pressure which acts on all surfaces. Then the momentum equations along the  $x$  and  $y$  axes become

$$F_{Rx} + P_{1,\text{gage}} A_1 = 0 - \beta \dot{m} (+V_1) = -\beta \dot{m} V$$

$$F_{Rz} = \beta \dot{m} (+V_2) = \beta \dot{m} V$$

Solving for  $F_{Rx}$  and  $F_{Rz}$ , and substituting the given values,

$$\begin{aligned} F_{Rx} &= -\beta \dot{m} V - P_{1,\text{gage}} A_1 \\ &= -1.03(40 \text{ kg/s})(5.093 \text{ m/s}) \left( \frac{1 \text{ N}}{1 \text{ kg} \cdot \text{m/s}^2} \right) - (4905 \text{ N/m}^2)[\pi(0.1 \text{ m})^2/4] \\ &= -248.4 \text{ N} \end{aligned}$$

$$F_{Ry} = \beta \dot{m} V = 1.03(40 \text{ kg/s})(5.093 \text{ m/s}) \left( \frac{1 \text{ N}}{1 \text{ kg} \cdot \text{m/s}^2} \right) = 209.8 \text{ N}$$

$$\text{and } F_R = \sqrt{F_{Rx}^2 + F_{Ry}^2} = \sqrt{(-248.4)^2 + (209.8)^2} = \mathbf{325 \text{ N}}, \quad \theta = \tan^{-1} \frac{F_{Ry}}{F_{Rx}} = \tan^{-1} \frac{209.8}{-248.4} = -40.2^\circ = \mathbf{140^\circ}$$

**Discussion** Note that the magnitude of the anchoring force is 325 N, and its line of action makes 140° from the positive  $x$  direction. Also, a negative value for  $F_{Rx}$  indicates the assumed direction is wrong, and should be reversed.

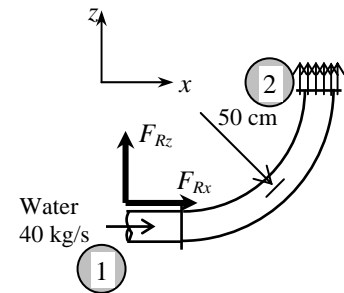

## 6-23

**Solution** A 180° elbow forces the flow to make a U-turn and discharges it to the atmosphere at a specified rate. The gage pressure at the inlet of the elbow and the anchoring force needed to hold the elbow in place are to be determined.

**Assumptions** 1 The flow is steady and incompressible. 2 Frictional effects are negligible in the calculation of the pressure drop (so that the Bernoulli equation can be used). 3 The weight of the elbow and the water in it is negligible. 4 The water is discharged to the atmosphere, and thus the gage pressure at the outlet is zero. 5 The momentum-flux correction factor for each inlet and outlet is given to be  $\beta = 1.03$ .

**Properties** We take the density of water to be  $1000 \text{ kg/m}^3$ .

**Analysis** (a) We take the elbow as the control volume, and designate the entrance by 1 and the outlet by 2. We also designate the horizontal coordinate by  $x$  (with the direction of flow as being the positive direction) and the vertical coordinate by  $z$ . The continuity equation for this one-inlet one-outlet steady flow system is  $\dot{m}_1 = \dot{m}_2 = \dot{m} = 40 \text{ kg/s}$ . Noting that  $\dot{m} = \rho AV$ , the mean inlet and outlet velocities of water are

$$V_1 = V_2 = V = \frac{\dot{m}}{\rho A} = \frac{\dot{m}}{\rho(\pi D^2 / 4)} = \frac{40 \text{ kg/s}}{(1000 \text{ kg/m}^3)[\pi(0.1 \text{ m})^2 / 4]} = 5.093 \text{ m/s}$$

Noting that  $V_1 = V_2$  and  $P_2 = P_{\text{atm}}$ , the Bernoulli equation for a streamline going through the center of the reducing elbow is expressed as

$$\frac{P_1}{\rho g} + \frac{V_1^2}{2g} + z_1 = \frac{P_2}{\rho g} + \frac{V_2^2}{2g} + z_2 \rightarrow P_1 - P_2 = \rho g(z_2 - z_1) \rightarrow P_{1,\text{gage}} = \rho g(z_2 - z_1)$$

Substituting,

$$P_{1,\text{gage}} = (1000 \text{ kg/m}^3)(9.81 \text{ m/s}^2)(1.0 \text{ m}) \left( \frac{1 \text{ kN}}{1000 \text{ kg} \cdot \text{m/s}^2} \right) = 9.810 \text{ kN/m}^2 \cong \mathbf{9.81 \text{ kPa}}$$

(b) The momentum equation for steady flow is  $\sum \vec{F} = \sum_{\text{out}} \beta \dot{m} \vec{V} - \sum_{\text{in}} \beta \dot{m} \vec{V}$ . We let the  $x$ - and  $z$ - components of the anchoring force of the elbow be  $F_{Rx}$  and  $F_{Rz}$ , and assume them to be in the positive directions. We also use gage pressures to avoid dealing with the atmospheric pressure which acts on all surfaces. Then the momentum equations along the  $x$  and  $z$  axes become

$$F_{Rx} + P_{1,\text{gage}} A_1 = \beta \dot{m}(-V_2) - \beta \dot{m}(+V_1) = -2\beta \dot{m}V$$

$$F_{Rz} = 0$$

Solving for  $F_{Rx}$  and substituting the given values,

$$F_{Rx} = -2\beta \dot{m}V - P_{1,\text{gage}} A_1$$

$$= -2 \times 1.03(40 \text{ kg/s})(5.093 \text{ m/s}) \left( \frac{1 \text{ N}}{1 \text{ kg} \cdot \text{m/s}^2} \right) - (9810 \text{ N/m}^2)[\pi(0.1 \text{ m})^2 / 4]$$

$$= -497 \text{ N}$$

and  $F_R = F_{Rx} = -497 \text{ N}$  since the  $y$ -component of the anchoring force is zero. Therefore, the anchoring force has a magnitude of 497 N and it acts in the negative  $x$  direction.

**Discussion** Note that a negative value for  $F_{Rx}$  indicates the assumed direction is wrong, and should be reversed.

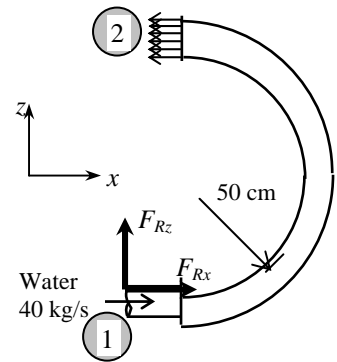

## 6-24E

**Solution** A horizontal water jet strikes a vertical stationary plate normally at a specified velocity. For a given anchoring force needed to hold the plate in place, the flow rate of water is to be determined.

**Assumptions** **1** The flow is steady and incompressible. **2** The water splatters off the sides of the plate in a plane normal to the jet. **3** The water jet is exposed to the atmosphere, and thus the pressure of the water jet and the splattered water is the atmospheric pressure which is disregarded since it acts on the entire control surface. **4** The vertical forces and momentum fluxes are not considered since they have no effect on the horizontal reaction force. **5** Jet flow is nearly uniform and thus the effect of the momentum-flux correction factor is negligible,  $\beta \cong 1$ .

**Properties** We take the density of water to be  $62.4 \text{ lbm/ft}^3$ .

**Analysis** We take the plate as the control volume such that it contains the entire plate and cuts through the water jet and the support bar normally, and the direction of flow as the positive direction of  $x$  axis. The momentum equation for steady flow in the  $x$  (flow) direction reduces in this case to

$$\sum \vec{F} = \sum_{\text{out}} \beta \dot{m} \vec{V} - \sum_{\text{in}} \beta \dot{m} \vec{V} \quad \rightarrow \quad -F_{Rx} = -\dot{m}V_1 \quad \rightarrow \quad F_R = \dot{m}V_1$$

We note that the reaction force acts in the opposite direction to flow, and we should not forget the negative sign for forces and velocities in the negative  $x$ -direction. Solving for  $\dot{m}$  and substituting the given values,

$$\dot{m} = \frac{F_{Rx}}{V_1} = \frac{350 \text{ lbf}}{25 \text{ ft/s}} \left( \frac{32.2 \text{ lbm} \cdot \text{ft/s}^2}{1 \text{ lbf}} \right) = 450.8 \text{ lbm/s}$$

Then the volume flow rate becomes

$$\dot{V} = \frac{\dot{m}}{\rho} = \frac{450.8 \text{ lbm/s}}{62.4 \text{ lbm/ft}^3} = \mathbf{7.22 \text{ ft}^3/\text{s}}$$

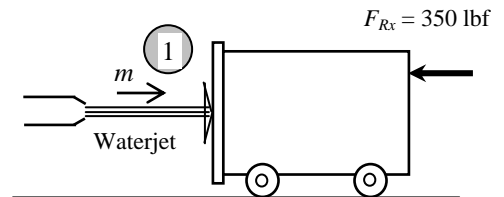

Therefore, the volume flow rate of water under stated assumptions must be  $7.22 \text{ ft}^3/\text{s}$ .

**Discussion** In reality, some water will be scattered back, and this will add to the reaction force of water. The flow rate in that case will be less.

## 6-25

**Solution** A reducing elbow deflects water upwards and discharges it to the atmosphere at a specified rate. The anchoring force needed to hold the elbow in place is to be determined.

**Assumptions** 1 The flow is steady and incompressible. 2 Frictional effects are negligible in the calculation of the pressure drop (so that the Bernoulli equation can be used). 3 The weight of the elbow and the water in it is considered. 4 The water is discharged to the atmosphere, and thus the gage pressure at the outlet is zero. 5 The momentum-flux correction factor for each inlet and outlet is given to be  $\beta = 1.03$ .

**Properties** We take the density of water to be  $1000 \text{ kg/m}^3$ .

**Analysis** The weight of the elbow and the water in it is

$$W = mg = (50 \text{ kg})(9.81 \text{ m/s}^2) = 490.5 \text{ N} = 0.4905 \text{ kN}$$

We take the elbow as the control volume, and designate the entrance by 1 and the outlet by 2. We also designate the horizontal coordinate by  $x$  (with the direction of flow as being the positive direction) and the vertical coordinate by  $z$ . The continuity equation for this one-inlet one-outlet steady flow system is  $\dot{m}_1 = \dot{m}_2 = \dot{m} = 30 \text{ kg/s}$ . Noting that  $\dot{m} = \rho AV$ , the inlet and outlet velocities of water are

$$V_1 = \frac{\dot{m}}{\rho A_1} = \frac{30 \text{ kg/s}}{(1000 \text{ kg/m}^3)(0.0150 \text{ m}^2)} = 2.0 \text{ m/s}$$

$$V_2 = \frac{\dot{m}}{\rho A_2} = \frac{30 \text{ kg/s}}{(1000 \text{ kg/m}^3)(0.0025 \text{ m}^2)} = 12 \text{ m/s}$$

Taking the center of the inlet cross section as the reference level ( $z_1 = 0$ ) and noting that  $P_2 = P_{\text{atm}}$ , the Bernoulli equation for a streamline going through the center of the reducing elbow is expressed as

$$\frac{P_1}{\rho g} + \frac{V_1^2}{2g} + z_1 = \frac{P_2}{\rho g} + \frac{V_2^2}{2g} + z_2 \rightarrow P_1 - P_2 = \rho g \left( \frac{V_2^2 - V_1^2}{2g} + z_2 - z_1 \right) \rightarrow P_{1,\text{gage}} = \rho g \left( \frac{V_2^2 - V_1^2}{2g} + z_2 \right)$$

Substituting,

$$P_{1,\text{gage}} = (1000 \text{ kg/m}^3)(9.81 \text{ m/s}^2) \left( \frac{(12 \text{ m/s})^2 - (2 \text{ m/s})^2}{2(9.81 \text{ m/s}^2)} + 0.4 \right) \left( \frac{1 \text{ kN}}{1000 \text{ kg} \cdot \text{m/s}^2} \right) = 73.9 \text{ kN/m}^2 = 73.9 \text{ kPa}$$

The momentum equation for steady flow is  $\sum \vec{F} = \sum_{\text{out}} \beta \dot{m} \vec{V} - \sum_{\text{in}} \beta \dot{m} \vec{V}$ . We let the  $x$ - and  $z$ - components of the anchoring force of the elbow be  $F_{Rx}$  and  $F_{Rz}$ , and assume them to be in the positive directions. We also use gage pressures to avoid dealing with the atmospheric pressure which acts on all surfaces. Then the momentum equations along the  $x$  and  $z$  axes become

$$F_{Rx} + P_{1,\text{gage}} A_1 = \beta \dot{m} V_2 \cos \theta - \beta \dot{m} V_1 \quad \text{and} \quad F_{Rz} - W = \beta \dot{m} V_2 \sin \theta$$

Solving for  $F_{Rx}$  and  $F_{Rz}$ , and substituting the given values,

$$F_{Rx} = \beta \dot{m} (V_2 \cos \theta - V_1) - P_{1,\text{gage}} A_1 = 1.03(30 \text{ kg/s})[(12 \cos 45^\circ - 2) \text{ m/s}] \left( \frac{1 \text{ kN}}{1000 \text{ kg} \cdot \text{m/s}^2} \right) - (73.9 \text{ kN/m}^2)(0.0150 \text{ m}^2)$$

$$= -0.908 \text{ kN}$$

$$F_{Rz} = \beta \dot{m} V_2 \sin \theta + W = 1.03(30 \text{ kg/s})(12 \sin 45^\circ \text{ m/s}) \left( \frac{1 \text{ kN}}{1000 \text{ kg} \cdot \text{m/s}^2} \right) + 0.4905 \text{ kN} = 0.753 \text{ kN}$$

$$F_R = \sqrt{F_{Rx}^2 + F_{Rz}^2} = \sqrt{(-0.908)^2 + (0.753)^2} = \mathbf{1.18 \text{ kN}}, \quad \theta = \tan^{-1} \frac{F_{Rz}}{F_{Rx}} = \tan^{-1} \frac{0.753}{-0.908} = \mathbf{-39.7^\circ}$$

**Discussion** Note that the magnitude of the anchoring force is  $1.18 \text{ kN}$ , and its line of action makes  $-39.7^\circ$  from  $+x$  direction. Negative value for  $F_{Rx}$  indicates the assumed direction is wrong.

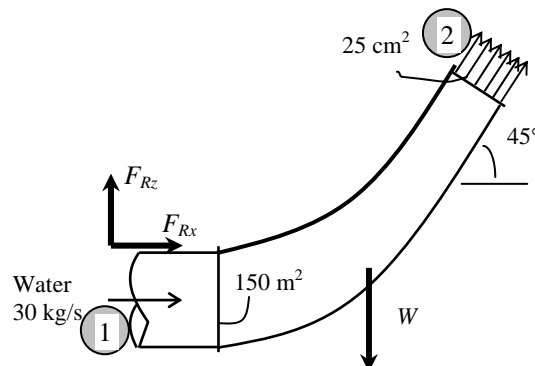

## 6-26

**Solution** A reducing elbow deflects water upwards and discharges it to the atmosphere at a specified rate. The anchoring force needed to hold the elbow in place is to be determined.

**Assumptions** 1 The flow is steady and incompressible. 2 Frictional effects are negligible in the calculation of the pressure drop (so that the Bernoulli equation can be used). 3 The weight of the elbow and the water in it is considered. 4 The water is discharged to the atmosphere, and thus the gage pressure at the outlet is zero. 5 The momentum-flux correction factor for each inlet and outlet is given to be  $\beta = 1.03$ .

**Properties** We take the density of water to be  $1000 \text{ kg/m}^3$ .

**Analysis** The weight of the elbow and the water in it is

$$W = mg = (50 \text{ kg})(9.81 \text{ m/s}^2) = 490.5 \text{ N} = 0.4905 \text{ kN}$$

We take the elbow as the control volume, and designate the entrance by 1 and the outlet by 2. We also designate the horizontal coordinate by  $x$  (with the direction of flow as being the positive direction) and the vertical coordinate by  $z$ . The continuity equation for this one-inlet one-outlet steady flow system is  $\dot{m}_1 = \dot{m}_2 = \dot{m} = 30 \text{ kg/s}$ . Noting that  $\dot{m} = \rho AV$ , the inlet and outlet velocities of water are

$$V_1 = \frac{\dot{m}}{\rho A_1} = \frac{30 \text{ kg/s}}{(1000 \text{ kg/m}^3)(0.0150 \text{ m}^2)} = 2.0 \text{ m/s}$$

$$V_2 = \frac{\dot{m}}{\rho A_2} = \frac{30 \text{ kg/s}}{(1000 \text{ kg/m}^3)(0.0025 \text{ m}^2)} = 12 \text{ m/s}$$

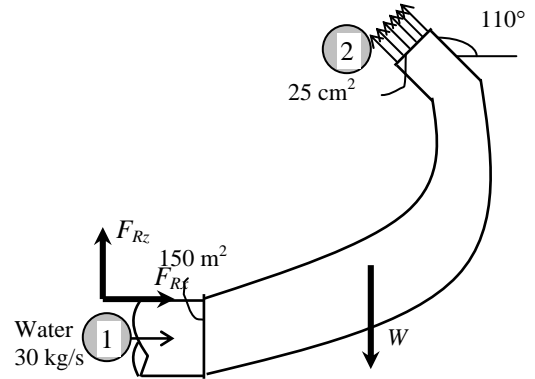

Taking the center of the inlet cross section as the reference level ( $z_1 = 0$ ) and noting that  $P_2 = P_{\text{atm}}$ , the Bernoulli equation for a streamline going through the center of the reducing elbow is expressed as

$$\frac{P_1}{\rho g} + \frac{V_1^2}{2g} + z_1 = \frac{P_2}{\rho g} + \frac{V_2^2}{2g} + z_2 \rightarrow P_1 - P_2 = \rho g \left( \frac{V_2^2 - V_1^2}{2g} + z_2 - z_1 \right) \rightarrow P_{1, \text{gage}} = \rho g \left( \frac{V_2^2 - V_1^2}{2g} + z_2 \right)$$

$$\text{or, } P_{1, \text{gage}} = (1000 \text{ kg/m}^3)(9.81 \text{ m/s}^2) \left( \frac{(12 \text{ m/s})^2 - (2 \text{ m/s})^2}{2(9.81 \text{ m/s}^2)} + 0.4 \right) \left( \frac{1 \text{ kN}}{1000 \text{ kg} \cdot \text{m/s}^2} \right) = 73.9 \text{ kN/m}^2 = 73.9 \text{ kPa}$$

The momentum equation for steady flow is  $\sum \vec{F} = \sum_{\text{out}} \beta \dot{m} \vec{V} - \sum_{\text{in}} \beta \dot{m} \vec{V}$ . We let the  $x$ - and  $y$ - components of the anchoring

force of the elbow be  $F_{Rx}$  and  $F_{Rz}$ , and assume them to be in the positive directions. We also use gage pressures to avoid dealing with the atmospheric pressure which acts on all surfaces. Then the momentum equations along the  $x$  and  $z$  axes become

$$F_{Rx} + P_{1, \text{gage}} A_1 = \beta \dot{m} V_2 \cos \theta - \beta \dot{m} V_1 \quad \text{and} \quad F_{Ry} - W = \beta \dot{m} V_2 \sin \theta$$

Solving for  $F_{Rx}$  and  $F_{Rz}$ , and substituting the given values,

$$F_{Rx} = \beta \dot{m} (V_2 \cos \theta - V_1) - P_{1, \text{gage}} A_1$$

$$= 1.03(30 \text{ kg/s})[(12 \cos 110^\circ - 2) \text{ m/s}] \left( \frac{1 \text{ kN}}{1000 \text{ kg} \cdot \text{m/s}^2} \right) - (73.9 \text{ kN/m}^2)(0.0150 \text{ m}^2) = -1.297 \text{ kN}$$

$$F_{Rz} = \beta \dot{m} V_2 \sin \theta + W = 1.03(30 \text{ kg/s})(12 \sin 110^\circ \text{ m/s}) \left( \frac{1 \text{ kN}}{1000 \text{ kg} \cdot \text{m/s}^2} \right) + 0.4905 \text{ kN} = 0.8389 \text{ kN}$$

$$F_R = \sqrt{F_{Rx}^2 + F_{Rz}^2} = \sqrt{(-1.297)^2 + 0.8389^2} = \mathbf{1.54 \text{ kN}}$$

and

$$\theta = \tan^{-1} \frac{F_{Rz}}{F_{Rx}} = \tan^{-1} \frac{0.8389}{-1.297} = \mathbf{-32.9^\circ}$$

**Discussion** Note that the magnitude of the anchoring force is 1.54 kN, and its line of action makes  $-32.9^\circ$  from  $+x$  direction. Negative value for  $F_{Rx}$  indicates assumed direction is wrong, and should be reversed.

## 6-27

**Solution** Water accelerated by a nozzle strikes the back surface of a cart moving horizontally at a constant velocity. The braking force and the power wasted by the brakes are to be determined.

**Assumptions** **1** The flow is steady and incompressible. **2** The water splatters off the sides of the plate in all directions in the plane of the back surface. **3** The water jet is exposed to the atmosphere, and thus the pressure of the water jet and the splattered water is the atmospheric pressure which is disregarded since it acts on all surfaces. **4** Friction during motion is negligible. **5** There is no acceleration of the cart. **7** The motions of the water jet and the cart are horizontal. **6** Jet flow is nearly uniform and thus the effect of the momentum-flux correction factor is negligible,  $\beta \cong 1$ .

**Analysis** We take the cart as the control volume, and the direction of flow as the positive direction of  $x$  axis. The relative velocity between the cart and the jet is

$$V_r = V_{\text{jet}} - V_{\text{cart}} = 35 - 10 = 25 \text{ m/s}$$

Therefore, we can view the cart as being stationary and the jet moving with a velocity of 25 m/s. Noting that water leaves the nozzle at 20 m/s and the corresponding mass flow rate relative to nozzle exit is 30 kg/s, the mass flow rate of water striking the cart corresponding to a water jet velocity of 25 m/s relative to the cart is

$$\dot{m}_r = \frac{V_r}{V_{\text{jet}}} \dot{m}_{\text{jet}} = \frac{25 \text{ m/s}}{35 \text{ m/s}} (30 \text{ kg/s}) = 21.43 \text{ kg/s}$$

The momentum equation for steady flow in the  $x$  (flow) direction reduces in this case to

$$\sum \vec{F} = \sum_{\text{out}} \beta \dot{m} \vec{V} - \sum_{\text{in}} \beta \dot{m} \vec{V} \quad \rightarrow \quad F_{R_x} = -\dot{m}_i V_i \quad \rightarrow \quad F_{\text{brake}} = -\dot{m}_r V_r$$

We note that the brake force acts in the opposite direction to flow, and we should not forget the negative sign for forces and velocities in the negative  $x$ -direction. Substituting the given values,

$$F_{\text{brake}} = -\dot{m}_r V_r = -(21.43 \text{ kg/s})(+25 \text{ m/s}) \left( \frac{1 \text{ N}}{1 \text{ kg} \cdot \text{m/s}^2} \right) = -535.8 \text{ N} \cong \mathbf{-536 \text{ N}}$$

The negative sign indicates that the braking force acts in the opposite direction to motion, as expected. Noting that work is force times distance and the distance traveled by the cart per unit time is the cart velocity, the power wasted by the brakes is

$$\dot{W} = F_{\text{brake}} V_{\text{cart}} = (535.8 \text{ N})(10 \text{ m/s}) \left( \frac{1 \text{ W}}{1 \text{ N} \cdot \text{m/s}} \right) = 5358 \text{ W} \cong \mathbf{5.36 \text{ kW}}$$

**Discussion** Note that the power wasted is equivalent to the maximum power that can be generated as the cart velocity is maintained constant.

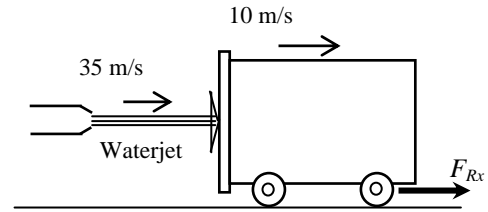



## 6-28

**Solution** Water accelerated by a nozzle strikes the back surface of a cart moving horizontally. The acceleration of the cart if the brakes fail is to be determined.

**Analysis** The braking force was determined in previous problem to be 535.8 N. When the brakes fail, this force will propel the cart forward, and the acceleration will be

$$a = \frac{F}{m_{\text{cart}}} = \frac{535.8 \text{ N}}{400 \text{ kg}} \left( \frac{1 \text{ kg} \cdot \text{m/s}^2}{1 \text{ N}} \right) = \mathbf{1.34 \text{ m/s}^2}$$

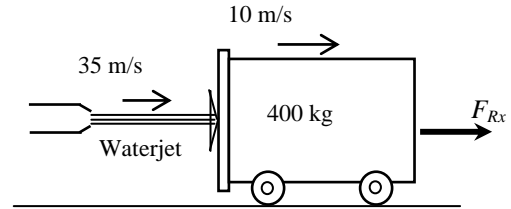

**Discussion** This is the acceleration at the moment the brakes fail. The acceleration will decrease as the relative velocity between the water jet and the cart (and thus the force) decreases.

## 6-29E

**Solution** A water jet hits a stationary splitter, such that half of the flow is diverted upward at  $45^\circ$ , and the other half is directed down. The force required to hold the splitter in place is to be determined.

**Assumptions** 1 The flow is steady and incompressible. 2 The water jet is exposed to the atmosphere, and thus the pressure of the water jet before and after the split is the atmospheric pressure which is disregarded since it acts on all surfaces. 3 The gravitational effects are disregarded. 4 The flow is nearly uniform at all cross sections, and thus the effect of the momentum-flux correction factor is negligible,  $\beta \cong 1$ .

**Properties** We take the density of water to be  $62.4 \text{ lbm/ft}^3$ .

**Analysis** The mass flow rate of water jet is

$$\dot{m} = \rho \dot{V} = (62.4 \text{ lbm/ft}^3)(100 \text{ ft}^3/\text{s}) = 6240 \text{ lbm/s}$$

We take the splitting section of water jet, including the splitter as the control volume, and designate the entrance by 1 and the outlet of either arm by 2 (both arms have the same velocity and mass flow rate). We also designate the horizontal coordinate by  $x$  with the direction of flow as being the positive direction and the vertical coordinate by  $z$ .

The momentum equation for steady flow is  $\sum \vec{F} = \sum_{\text{out}} \beta \dot{m} \vec{V} - \sum_{\text{in}} \beta \dot{m} \vec{V}$ . We let the  $x$ - and  $y$ - components of the anchoring force of the splitter be  $F_{Rx}$  and  $F_{Rz}$ , and assume them to be in the positive directions. Noting that  $V_2 = V_1 = V$  and  $\dot{m}_2 = \frac{1}{2} \dot{m}$ , the momentum equations along the  $x$  and  $z$  axes become

$$F_{Rx} = 2\left(\frac{1}{2} \dot{m}\right)V_2 \cos \theta - \dot{m}V_1 = \dot{m}V(\cos \theta - 1)$$

$$F_{Rz} = \frac{1}{2} \dot{m}(+V_2 \sin \theta) + \frac{1}{2} \dot{m}(-V_2 \sin \theta) - 0 = 0$$

Substituting the given values,

$$F_{Rx} = (6240 \text{ lbm/s})(18 \text{ ft/s})(\cos 45^\circ - 1) \left( \frac{1 \text{ lbf}}{32.2 \text{ lbm} \cdot \text{ft/s}^2} \right) = -1021.67 \text{ lbf} \cong \mathbf{-1020 \text{ lbf}}$$

$$F_{Rz} = \mathbf{0}$$

The negative value for  $F_{Rx}$  indicates the assumed direction is wrong, and should be reversed. Therefore, a force of 1020 lbf must be applied to the splitter in the opposite direction to flow to hold it in place. No holding force is necessary in the vertical direction. This can also be concluded from the symmetry.

**Discussion** In reality, the gravitational effects will cause the upper stream to slow down and the lower stream to speed up after the split. But for short distances, these effects are indeed negligible.

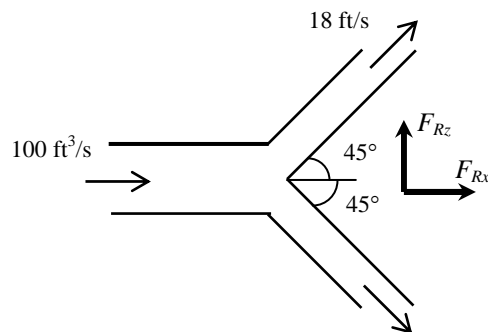

6-30E 

**Solution** The previous problem is reconsidered. The effect of splitter angle on the force exerted on the splitter as the half splitter angle varies from 0 to 180° in increments of 10° is to be investigated.

**Analysis** The EES *Equations* window is printed below, followed by the tabulated and plotted results.

```

g=32.2 "ft/s2"
rho=62.4 "lbm/ft3"
V_dot=100 "ft3/s"
V=20 "ft/s"
m_dot=rho*V_dot
F_R=-m_dot*V*(cos(theta)-1)/g "lbf"

```

$\theta, ^\circ$	$\dot{m}$ , lbm/s	$F_R$ , lbf
0	6240	0
10	6240	59
20	6240	234
30	6240	519
40	6240	907
50	6240	1384
60	6240	1938
70	6240	2550
80	6240	3203
90	6240	3876
100	6240	4549
110	6240	5201
120	6240	5814
130	6240	6367
140	6240	6845
150	6240	7232
160	6240	7518
170	6240	7693
180	6240	7752

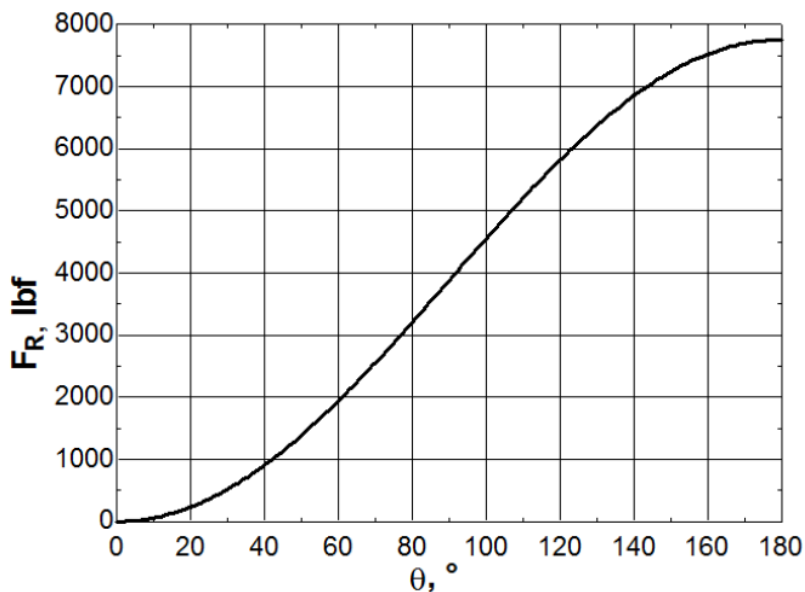

**Discussion** The force rises from zero at  $\theta = 0^\circ$  to a maximum at  $\theta = 180^\circ$ , as expected, but the relationship is not linear.

## 6-31

**Solution** A horizontal water jet impinges normally upon a vertical plate which is held on a frictionless track and is initially stationary. The initial acceleration of the plate, the time it takes to reach a certain velocity, and the velocity at a given time are to be determined.

**Assumptions** **1** The flow is steady and incompressible. **2** The water always splatters in the plane of the retreating plate. **3** The water jet is exposed to the atmosphere, and thus the pressure of the water jet and the splattered water is the atmospheric pressure which is disregarded since it acts on all surfaces. **4** The track is nearly frictionless, and thus friction during motion is negligible. **5** The motions of the water jet and the cart are horizontal. **6** The velocity of the jet relative to the plate remains constant,  $V_r = V_{\text{jet}} = V$ . **7** Jet flow is nearly uniform and thus the effect of the momentum-flux correction factor is negligible,  $\beta \cong 1$ .

**Properties** We take the density of water to be  $1000 \text{ kg/m}^3$ .

**Analysis** (a) We take the vertical plate on the frictionless track as the control volume, and the direction of flow as the positive direction of  $x$  axis. The mass flow rate of water in the jet is

$$\dot{m} = \rho VA = (1000 \text{ kg/m}^3)(18 \text{ m/s})[\pi(0.05 \text{ m})^2 / 4] = 35.34 \text{ kg/s}$$

The momentum equation for steady flow in the  $x$  (flow) direction reduces in this case to

$$\sum \vec{F} = \sum_{\text{out}} \beta \dot{m} \vec{V} - \sum_{\text{in}} \beta \dot{m} \vec{V} \quad \rightarrow \quad F_{Rx} = -\dot{m}_i V_i \quad \rightarrow \quad F_{Rx} = -\dot{m} V$$

where  $F_{Rx}$  is the reaction force required to hold the plate in place. When the plate is released, an equal and opposite impulse force acts on the plate, which is determined to

$$F_{\text{plate}} = -F_{Rx} = \dot{m} V = (35.34 \text{ kg/s})(18 \text{ m/s}) \left( \frac{1 \text{ N}}{1 \text{ kg} \cdot \text{m/s}^2} \right) = 636 \text{ N}$$

Then the initial acceleration of the plate becomes

$$a = \frac{F_{\text{plate}}}{m_{\text{plate}}} = \frac{636 \text{ N}}{1000 \text{ kg}} \left( \frac{1 \text{ kg} \cdot \text{m/s}^2}{1 \text{ N}} \right) = \mathbf{0.636 \text{ m/s}^2}$$

This acceleration will remain constant during motion since the force acting on the plate remains constant.

(b) Noting that  $a = dV/dt = \Delta V/\Delta t$  since the acceleration  $a$  is constant, the time it takes for the plate to reach a velocity of 9 m/s is

$$\Delta t = \frac{\Delta V_{\text{plate}}}{a} = \frac{(9 - 0) \text{ m/s}}{0.636 \text{ m/s}^2} = \mathbf{14.2 \text{ s}}$$

(c) Noting that  $a = dV/dt$  and thus  $dV = a dt$  and that the acceleration  $a$  is constant, the plate velocity in 20 s becomes

$$V_{\text{plate}} = V_{0, \text{plate}} + a \Delta t = 0 + (0.636 \text{ m/s}^2)(20 \text{ s}) = \mathbf{12.7 \text{ m/s}}$$

**Discussion** The assumption that the relative velocity between the water jet and the plate remains constant is valid only for the initial moments of motion when the plate velocity is low unless the water jet is moving with the plate at the same velocity as the plate.

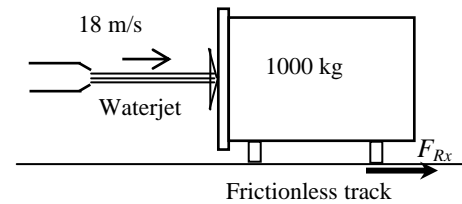

## 6-32E

**Solution** A fan moves air at sea level at a specified rate. The force required to hold the fan and the minimum power input required for the fan are to be determined.

**Assumptions** 1 The flow of air is steady and incompressible. 2 Standard atmospheric conditions exist so that the pressure at sea level is 1 atm. 3 Air leaves the fan at a uniform velocity at atmospheric pressure. 4 Air approaches the fan through a large area at atmospheric pressure with negligible velocity. 5 The frictional effects are negligible, and thus the entire mechanical power input is converted to kinetic energy of air (no conversion to thermal energy through frictional effects). 6 Wind flow is nearly uniform and thus the momentum-flux correction factor can be taken to be unity,  $\beta \cong 1$ .

**Properties** The gas constant of air is  $R = 0.3704$  psi·ft<sup>3</sup>/lbm·R. The standard atmospheric pressure at sea level is 1 atm = 14.7 psi.

**Analysis** (a) We take the control volume to be a horizontal hyperbolic cylinder bounded by streamlines on the sides with air entering through the large cross-section (section 1) and the fan located at the narrow cross-section at the end (section 2), and let its centerline be the  $x$  axis. The density, mass flow rate, and discharge velocity of air are

$$\rho = \frac{P}{RT} = \frac{14.7 \text{ psi}}{(0.3704 \text{ psi} \cdot \text{ft}^3/\text{lbm} \cdot \text{R})(530 \text{ R})} = 0.0749 \text{ lbm/ft}^3$$

$$\dot{m} = \rho \dot{V} = (0.0749 \text{ lbm/ft}^3)(2000 \text{ ft}^3/\text{min}) = 149.8 \text{ lbm/min} = 2.50 \text{ lbm/s}$$

$$V_2 = \frac{\dot{V}}{A_2} = \frac{\dot{V}}{\pi D_2^2 / 4} = \frac{2000 \text{ ft}^3/\text{min}}{\pi (2 \text{ ft})^2 / 4} = 636.6 \text{ ft/min} = 10.6 \text{ ft/s}$$

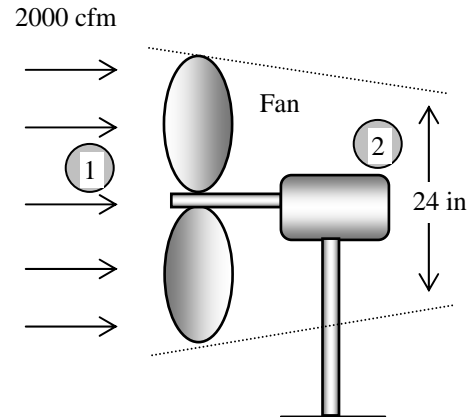

The momentum equation for steady flow is  $\sum \vec{F} = \sum_{\text{out}} \beta \dot{m} \vec{V} - \sum_{\text{in}} \beta \dot{m} \vec{V}$ . Letting the reaction force to hold the fan be  $F_{Rx}$  and assuming it to be in the positive  $x$  (i.e., the flow) direction, the momentum equation along the  $x$  axis becomes

$$F_{Rx} = \dot{m}(V_2) - 0 = \dot{m}V = (2.50 \text{ lbm/s})(10.6 \text{ ft/s}) \left( \frac{1 \text{ lbf}}{32.2 \text{ lbm} \cdot \text{ft/s}^2} \right) = \mathbf{0.820 \text{ lbf}}$$

Therefore, a force of 0.82 lbf must be applied (through friction at the base, for example) to prevent the fan from moving in the horizontal direction under the influence of this force.

(b) Noting that  $P_1 = P_2 = P_{\text{atm}}$  and  $V_1 \cong 0$ , the energy equation for the selected control volume reduces to

$$\dot{m} \left( \frac{P_1}{\rho} + \frac{V_1^2}{2} + gz_1 \right) + \dot{W}_{\text{pump,u}} = \dot{m} \left( \frac{P_2}{\rho} + \frac{V_2^2}{2} + gz_2 \right) + \dot{W}_{\text{turbine}} + \dot{E}_{\text{mech,loss}} \rightarrow \dot{W}_{\text{fan,u}} = \dot{m} \frac{V_2^2}{2}$$

Substituting,

$$\dot{W}_{\text{fan,u}} = \dot{m} \frac{V_2^2}{2} = (2.50 \text{ lbm/s}) \frac{(10.6 \text{ ft/s})^2}{2} \left( \frac{1 \text{ lbf}}{32.2 \text{ lbm} \cdot \text{ft/s}^2} \right) \left( \frac{1 \text{ W}}{0.73756 \text{ lbf} \cdot \text{ft/s}} \right) = \mathbf{5.91 \text{ W}}$$

Therefore, a useful mechanical power of 5.91 W must be supplied to air. This is the *minimum* required power input required for the fan.

**Discussion** The actual power input to the fan will be larger than 5.91 W because of the fan inefficiency in converting mechanical power to kinetic energy.

## 6-33E

**Solution** A horizontal water jet strikes a bent plate, which deflects the water by  $135^\circ$  from its original direction. The force required to hold the plate against the water stream is to be determined.

**Assumptions** **1** The flow is steady and incompressible. **2** The water jet is exposed to the atmosphere, and thus the pressure of the water jet and the splattered water is the atmospheric pressure, which is disregarded since it acts on all surfaces. **3** Frictional and gravitational effects are negligible. **4** There is no splattering of water or the deformation of the jet, and the reversed jet leaves at the same velocity and flow rate. **5** Jet flow is nearly uniform and thus the momentum-flux correction factor is nearly unity,  $\beta \cong 1$ .

**Properties** We take the density of water to be  $62.4 \text{ lbm/ft}^3$ .

**Analysis** We take the plate together with the curved water jet as the control volume, and designate the jet inlet by 1 and the outlet by 2. We also designate the horizontal coordinate by  $x$  (with the direction of incoming flow as being the positive direction), and the vertical coordinate by  $z$ . The equation of conservation of mass for this one-inlet one-outlet steady flow system is  $\dot{m}_1 = \dot{m}_2 = \dot{m}$  where

$$\dot{m} = \rho VA = \rho V[\pi D^2 / 4] = (62.4 \text{ lbm/ft}^3)(140 \text{ ft/s})[\pi(3/12 \text{ ft})^2 / 4] = 428.8 \text{ lbm/s}$$

The momentum equation for steady flow is  $\sum \vec{F} = \sum_{\text{out}} \beta \dot{m} \vec{V} - \sum_{\text{in}} \beta \dot{m} \vec{V}$ . We let the  $x$ - and  $z$ - components of the anchoring force of the plate be  $F_{Rx}$  and  $F_{Rz}$ , and assume them to be in the positive directions. Then the momentum equations along the  $x$  and  $y$  axes become

$$F_{Rx} = \dot{m}(-V_2) \cos 45^\circ - \dot{m}(+V_1) = -\dot{m}V(1 + \cos 45^\circ)$$

$$F_{Rz} = \dot{m}(+V_2) \sin 45^\circ = \dot{m}V \sin 45^\circ$$

Substituting the given values,

$$F_{Rx} = -(428.8 \text{ lbm/s})(140 \text{ ft/s})(1 + \cos 45^\circ) \left( \frac{1 \text{ lbf}}{32.2 \text{ lbm} \cdot \text{ft/s}^2} \right)$$

$$= -3182.64 \text{ lbf} \cong -3180 \text{ lbf}$$

$$F_{Rz} = (428.8 \text{ lbm/s})(140 \text{ ft/s}) \sin 45^\circ \left( \frac{1 \text{ lbf}}{32.2 \text{ lbm} \cdot \text{ft/s}^2} \right) = 1318.29 \text{ lbf} \cong 1320 \text{ lbf}$$

and

$$F_R = \sqrt{F_{Rx}^2 + F_{Rz}^2} = \sqrt{(-3182.64)^2 + 1318.29^2} = 3444.86 \text{ lbf} \cong \mathbf{3440 \text{ lbf}}, \quad \theta = \tan^{-1} \frac{F_{Ry}}{F_{Rx}} = \tan^{-1} \frac{1318.29}{-3182.64} = 157.50^\circ \cong \mathbf{158^\circ}$$

**Discussion** Note that the magnitude of the anchoring force is 3440 lbf, and its line of action is  $158^\circ$  from the positive  $x$  direction. Also, a negative value for  $F_{Rx}$  indicates the assumed direction is wrong; the actual anchoring force is to the left. This makes sense when we think about it; with the water jet striking the plate from left to right, one would have to push to the left in order to hold the plate in place.

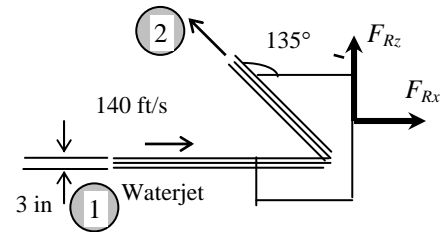

## 6-34

**Solution** Firemen are holding a nozzle at the end of a hose while trying to extinguish a fire. The average water outlet velocity and the resistance force required of the firemen to hold the nozzle are to be determined.

**Assumptions** **1** The flow is steady and incompressible. **2** The water jet is exposed to the atmosphere, and thus the pressure of the water jet is the atmospheric pressure, which is disregarded since it acts on all surfaces. **3** Gravitational effects and vertical forces are disregarded since the horizontal resistance force is to be determined. **5** Jet flow is nearly uniform and thus the momentum-flux correction factor can be taken to be unity,  $\beta \cong 1$ .

**Properties** We take the density of water to be  $1000 \text{ kg/m}^3$ .

**Analysis** (a) We take the nozzle and the horizontal portion of the hose as the system such that water enters the control volume vertically and outlets horizontally (this way the pressure force and the momentum flux at the inlet are in the vertical direction, with no contribution to the force balance in the horizontal direction), and designate the entrance by 1 and the outlet by 2. We also designate the horizontal coordinate by  $x$  (with the direction of flow as being the positive direction). The average outlet velocity and the mass flow rate of water are determined from

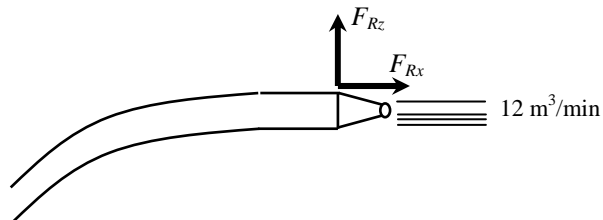

$$V = \frac{\dot{V}}{A} = \frac{\dot{V}}{\pi D^2 / 4} = \frac{12 \text{ m}^3/\text{min}}{\pi (0.08 \text{ m})^2 / 4} = 2387 \text{ m/min} = 39.79 \text{ m/s} \cong \mathbf{39.8 \text{ m/s}}$$

$$\dot{m} = \rho \dot{V} = (1000 \text{ kg/m}^3)(12 \text{ m}^3/\text{min}) = 12,000 \text{ kg/min} = 200 \text{ kg/s}$$

(b) The momentum equation for steady flow is  $\sum \vec{F} = \sum_{\text{out}} \beta \dot{m} \vec{V} - \sum_{\text{in}} \beta \dot{m} \vec{V}$ . We let horizontal force applied by the firemen to the nozzle to hold it be  $F_{Rx}$ , and assume it to be in the positive  $x$  direction. Then the momentum equation along the  $x$  direction gives

$$F_{Rx} = \dot{m} V_e - 0 = \dot{m} V = (200 \text{ kg/s})(39.79 \text{ m/s}) \left( \frac{1 \text{ N}}{1 \text{ kg} \cdot \text{m/s}^2} \right) = \mathbf{-7958 \text{ N}}$$

Therefore, the firemen must be able to resist a force of 7958 N to hold the nozzle in place.

**Discussion** The force of 7958 N is equivalent to the weight of about 810 kg. That is, holding the nozzle requires the strength of holding a weight of 810 kg, which cannot be done by a single person. This demonstrates why several firemen are used to hold a hose with a high flow rate.

## 6-35

**Solution** A horizontal jet of water with a given velocity strikes a flat plate that is moving in the same direction at a specified velocity. The force that the water stream exerts against the plate is to be determined.

**Assumptions** 1 The flow is steady and incompressible. 2 The water splatters in all directions in the plane of the plate. 3 The water jet is exposed to the atmosphere, and thus the pressure of the water jet and the splattered water is the atmospheric pressure, which is disregarded since it acts on all surfaces. 4 The vertical forces and momentum fluxes are not considered since they have no effect on the horizontal force exerted on the plate. 5 The velocity of the plate, and the velocity of the water jet relative to the plate, are constant. 6 Jet flow is nearly uniform and thus the momentum-flux correction factor can be taken to be unity,  $\beta \cong 1$ .

**Properties** We take the density of water to be  $1000 \text{ kg/m}^3$ .

**Analysis** We take the plate as the control volume, and the flow direction as the positive direction of  $x$  axis. The relative velocity between the plate and the jet is

$$V_r = V_{\text{jet}} - V_{\text{plate}} = 40 - 10 = 30 \text{ m/s}$$

Therefore, we can view the plate as being stationary and the jet to be moving with a velocity of 30 m/s. The mass flow rate of water relative to the plate [i.e., the flow rate at which water strikes the plate] is

$$\dot{m}_r = \rho V_r A = \rho V_r \frac{\pi D^2}{4} = (1000 \text{ kg/m}^3)(30 \text{ m/s}) \frac{\pi (0.05 \text{ m})^2}{4} = 58.90 \text{ kg/s}$$

The momentum equation for steady flow is  $\sum \vec{F} = \sum_{\text{out}} \beta \dot{m} \vec{V} - \sum_{\text{in}} \beta \dot{m} \vec{V}$ . We let the horizontal reaction force applied to the plate in the negative  $x$  direction to counteract the impulse of the water jet be  $F_{Rx}$ . Then the momentum equation along the  $x$  direction gives

$$-F_{Rx} = 0 - \dot{m} V_i \rightarrow F_{Rx} = \dot{m}_r V_r = (58.90 \text{ kg/s})(30 \text{ m/s}) \left( \frac{1 \text{ N}}{1 \text{ kg} \cdot \text{m/s}^2} \right) = \mathbf{1767 \text{ N}}$$

Therefore, the water jet applies a force of 1767 N on the plate in the direction of motion, and an equal and opposite force must be applied on the plate if its velocity is to remain constant.

**Discussion** Note that we used the relative velocity in the determination of the mass flow rate of water in the momentum analysis since water will enter the control volume at this rate. (In the limiting case of the plate and the water jet moving at the same velocity, the mass flow rate of water relative to the plate will be zero since no water will be able to strike the plate).

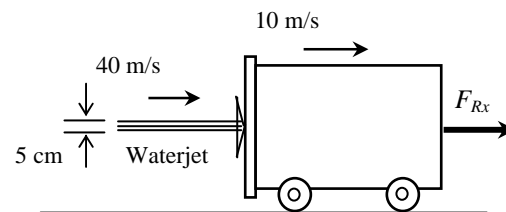



6-36



**Solution** The previous problem is reconsidered. The effect of the plate velocity on the force exerted on the plate as the plate velocity varies from 0 to 30 m/s in increments of 3 m/s is to be investigated.

**Analysis** The EES *Equations* window is printed below, followed by the tabulated and plotted results.

```
rho=1000 "kg/m3"
D=0.05 "m"
V_jet=30 "m/s"

Ac=pi*D^2/4
V_r=V_jet-V_plate
m_dot=rho*Ac*V_r
F_R=m_dot*V_r "N"
```

$V_{\text{plate}}$ , m/s	$V_r$ , m/s	$F_R$ , N
0	30	1767
3	27	1431
6	24	1131
9	21	866
12	18	636
15	15	442
18	12	283
21	9	159
24	6	70.7
27	3	17.7
30	0	0

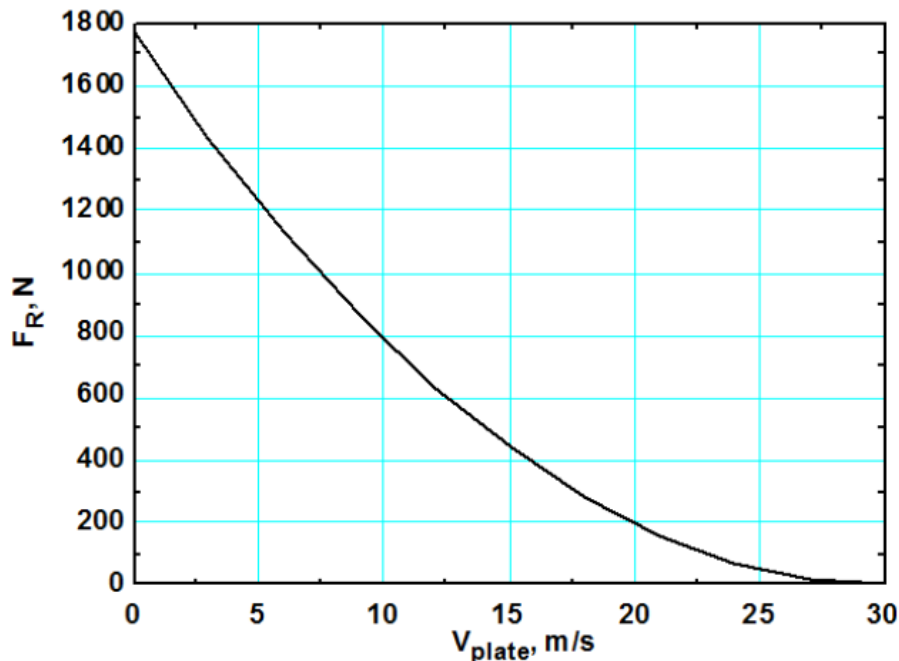

**Discussion** When the plate velocity reaches 30 m/s, there is no relative motion between the jet and the plate; hence, there can be no force acting.

## 6-37E

**Solution** A horizontal water jet strikes a curved plate, which deflects the water back to its original direction. The force required to hold the plate against the water stream is to be determined.

**Assumptions** **1** The flow is steady and incompressible. **2** The water jet is exposed to the atmosphere, and thus the pressure of the water jet and the splattered water is the atmospheric pressure, which is disregarded since it acts on all surfaces. **3** Friction between the plate and the surface it is on is negligible (or the friction force can be included in the required force to hold the plate). **4** There is no splashing of water or the deformation of the jet, and the reversed jet leaves horizontally at the same velocity and flow rate. **5** Jet flow is nearly uniform and thus the momentum-flux correction factor is nearly unity,  $\beta \cong 1$ .

**Properties** We take the density of water to be  $62.4 \text{ lbm/ft}^3$ .

**Analysis** We take the plate together with the curved water jet as the control volume, and designate the jet inlet by 1 and the outlet by 2. We also designate the horizontal coordinate by  $x$  (with the direction of incoming flow as being the positive direction). The continuity equation for this one-inlet one-outlet steady flow system is  $\dot{m}_1 = \dot{m}_2 = \dot{m}$  where

$$\dot{m} = \rho VA = \rho V[\pi D^2 / 4] = (62.4 \text{ lbm/ft}^3)(90 \text{ ft/s})[\pi(3/12 \text{ ft})^2 / 4] = 275.7 \text{ lbm/s}$$

The momentum equation for steady flow is  $\sum \vec{F} = \sum_{\text{out}} \beta \dot{m} \vec{V} - \sum_{\text{in}} \beta \dot{m} \vec{V}$ . Letting the reaction force to hold the plate be  $F_{Rx}$  and assuming it to be in the positive direction, the momentum equation along the  $x$  axis becomes

$$F_{Rx} = \dot{m}(-V_2) - \dot{m}(+V_1) = -2\dot{m}V$$

Substituting,

$$F_{Rx} = -2(275.7 \text{ lbm/s})(90 \text{ ft/s})\left(\frac{1 \text{ lbf}}{32.2 \text{ lbm} \cdot \text{ft/s}^2}\right) = -1541 \text{ lbf} \cong \mathbf{-1540 \text{ lbf}}$$

Therefore, a force of 1540 lbf must be applied on the plate in the negative  $x$  direction to hold it in place.

**Discussion** Note that a negative value for  $F_{Rx}$  indicates the assumed direction is wrong (as expected), and should be reversed. Also, there is no need for an analysis in the vertical direction since the fluid streams are horizontal.

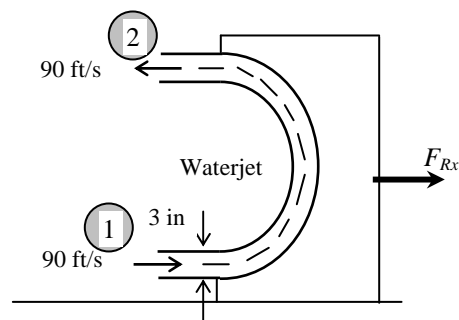

## 6-38

**Solution** A helicopter hovers at sea level while being loaded. The volumetric air flow rate and the required power input during unloaded hover, and the rpm and the required power input during loaded hover are to be determined.

**Assumptions** **1** The flow of air is steady and incompressible. **2** Air leaves the blades at a uniform velocity at atmospheric pressure. **3** Air approaches the blades from the top through a large area at atmospheric pressure with negligible velocity. **4** The frictional effects are negligible, and thus the entire mechanical power input is converted to kinetic energy of air (no conversion to thermal energy through frictional effects). **5** The change in air pressure with elevation is negligible because of the low density of air. **6** There is no acceleration of the helicopter, and thus the lift generated is equal to the total weight. **7** Air flow is nearly uniform and thus the momentum-flux correction factor can be taken to be unity,  $\beta \cong 1$ .

**Properties** The density of air is given to be  $1.18 \text{ kg/m}^3$ .

**Analysis** (a) We take the control volume to be a vertical hyperbolic cylinder bounded by streamlines on the sides with air entering through the large cross-section (section 1) at the top and the fan located at the narrow cross-section at the bottom (section 2), and let its centerline be the  $z$  axis with upwards being the positive direction.

The momentum equation for steady flow is  $\sum \vec{F} = \sum_{\text{out}} \beta \dot{m} \vec{V} - \sum_{\text{in}} \beta \dot{m} \vec{V}$ . Noting that the only force acting on the control volume is the total weight  $W$  and it acts in the negative  $z$  direction, the momentum equation along the  $z$  axis gives

$$-W = \dot{m}(-V_2) - 0 \quad \rightarrow \quad W = \dot{m}V_2 = (\rho AV_2)V_2 = \rho AV_2^2 \quad \rightarrow \quad V_2 = \sqrt{\frac{W}{\rho A}}$$

where  $A$  is the blade span area,

$$A = \pi D^2 / 4 = \pi (18 \text{ m})^2 / 4 = 254.5 \text{ m}^2$$

Then the discharge velocity, volume flow rate, and the mass flow rate of air in the unloaded mode become

$$V_{2,\text{unloaded}} = \sqrt{\frac{m_{\text{unloaded}} g}{\rho A}} = \sqrt{\frac{(12,000 \text{ kg})(9.81 \text{ m/s}^2)}{(1.18 \text{ kg/m}^3)(254.5 \text{ m}^2)}} = 19.80 \text{ m/s}$$

$$\dot{V}_{\text{unloaded}} = AV_{2,\text{unloaded}} = (254.5 \text{ m}^2)(19.80 \text{ m/s}) = \mathbf{5039 \text{ m}^3/\text{s}}$$

$$\dot{m}_{\text{unloaded}} = \rho \dot{V}_{\text{unloaded}} = (1.18 \text{ kg/m}^3)(5039 \text{ m}^3/\text{s}) = 5946 \text{ kg/s}$$

Noting that  $P_1 = P_2 = P_{\text{atm}}$ ,  $V_1 \cong 0$ , the elevation effects are negligible, and the frictional effects are disregarded, the energy equation for the selected control volume reduces to

$$\dot{m} \left( \frac{P_1}{\rho} + \frac{V_1^2}{2} + gz_1 \right) + \dot{W}_{\text{pump,u}} = \dot{m} \left( \frac{P_2}{\rho} + \frac{V_2^2}{2} + gz_2 \right) + \dot{W}_{\text{turbine}} + \dot{E}_{\text{mech,loss}} \quad \rightarrow \quad \dot{W}_{\text{fan,u}} = \dot{m} \frac{V_2^2}{2}$$

Substituting,

$$\dot{W}_{\text{unloaded fan,u}} = \left( \dot{m} \frac{V_2^2}{2} \right)_{\text{unloaded}} = (5946 \text{ kg/s}) \frac{(19.80 \text{ m/s})^2}{2} \left( \frac{1 \text{ kN}}{1000 \text{ kg} \cdot \text{m/s}^2} \right) \left( \frac{1 \text{ kW}}{1 \text{ kN} \cdot \text{m/s}} \right) = 1165 \text{ kW} \cong \mathbf{1170 \text{ kW}}$$

(b) We now repeat the calculations for the *loaded* helicopter, whose mass is  $12,000 + 14,000 = 26,000 \text{ kg}$ :

$$V_{2,\text{loaded}} = \sqrt{\frac{m_{\text{loaded}} g}{\rho A}} = \sqrt{\frac{(26,000 \text{ kg})(9.81 \text{ m/s}^2)}{(1.18 \text{ kg/m}^3)(254.5 \text{ m}^2)}} = 29.14 \text{ m/s}$$

$$\dot{m}_{\text{loaded}} = \rho \dot{V}_{\text{loaded}} = \rho AV_{2,\text{loaded}} = (1.18 \text{ kg/m}^3)(254.5 \text{ m}^2)(29.14 \text{ m/s}) = 8752 \text{ kg/s}$$

$$\dot{W}_{\text{loaded fan,u}} = \left( \dot{m} \frac{V_2^2}{2} \right)_{\text{loaded}} = (8752 \text{ kg/s}) \frac{(29.14 \text{ m/s})^2}{2} \left( \frac{1 \text{ kN}}{1000 \text{ kg} \cdot \text{m/s}^2} \right) \left( \frac{1 \text{ kW}}{1 \text{ kN} \cdot \text{m/s}} \right) = 3716 \text{ kW} \cong \mathbf{3720 \text{ kW}}$$

Noting that the average flow velocity is proportional to the overhead blade rotational velocity, the rpm of the loaded helicopter blades becomes

$$V_2 = kn \quad \rightarrow \quad \frac{V_{2,\text{loaded}}}{V_{2,\text{unloaded}}} = \frac{\dot{n}_{\text{loaded}}}{\dot{n}_{\text{unloaded}}} \quad \rightarrow \quad \dot{n}_{\text{loaded}} = \frac{V_{2,\text{loaded}}}{V_{2,\text{unloaded}}} \dot{n}_{\text{unloaded}} = \frac{29.14}{19.80} (550 \text{ rpm}) = \mathbf{809 \text{ rpm}}$$

**Discussion** The actual power input to the helicopter blades will be considerably larger than the calculated power input because of the fan inefficiency in converting mechanical power to kinetic energy.

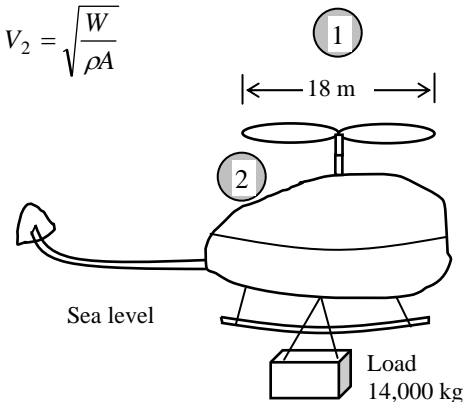

## 6-39

**Solution** A helicopter hovers on top of a high mountain where the air density considerably lower than that at sea level. The blade rotational velocity to hover at the higher altitude and the percent increase in the required power input to hover at high altitude relative to that at sea level are to be determined.

**Assumptions** **1** The flow of air is steady and incompressible. **2** The air leaves the blades at a uniform velocity at atmospheric pressure. **3** Air approaches the blades from the top through a large area at atmospheric pressure with negligible velocity. **4** The frictional effects are negligible, and thus the entire mechanical power input is converted to kinetic energy of air. **5** The change in air pressure with elevation while hovering at a given location is negligible because of the low density of air. **6** There is no acceleration of the helicopter, and thus the lift generated is equal to the total weight. **7** Air flow is nearly uniform and thus the momentum-flux correction factor can be taken to be unity,  $\beta \cong 1$ .

**Properties** The density of air is given to be  $1.18 \text{ kg/m}^3$  at sea level, and  $0.928 \text{ kg/m}^3$  on top of the mountain.

**Analysis** (a) We take the control volume to be a vertical hyperbolic cylinder bounded by streamlines on the sides with air entering through the large cross-section (section 1) at the top and the fan located at the narrow cross-section at the bottom (section 2), and let its centerline be the  $z$  axis with upwards being the positive direction.

The momentum equation for steady flow is  $\sum \vec{F} = \sum_{\text{out}} \beta \dot{m} \vec{V} - \sum_{\text{in}} \beta \dot{m} \vec{V}$ . Noting that the only force acting on the control volume is the total weight  $W$  and it acts in the negative  $z$  direction, the momentum equation along the  $z$  axis gives

$$-W = \dot{m}(-V_2) - 0 \quad \rightarrow \quad W = \dot{m}V_2 = (\rho AV_2)V_2 = \rho AV_2^2 \quad \rightarrow \quad V_2 = \sqrt{\frac{W}{\rho A}}$$

where  $A$  is the blade span area. Then for a given weight  $W$ , the ratio of discharge velocities becomes

$$\frac{V_{2,\text{mountain}}}{V_{2,\text{sea}}} = \frac{\sqrt{W/\rho_{\text{mountain}}A}}{\sqrt{W/\rho_{\text{sea}}A}} = \sqrt{\frac{\rho_{\text{sea}}}{\rho_{\text{mountain}}}} = \sqrt{\frac{1.18 \text{ kg/m}^3}{0.928 \text{ kg/m}^3}} = 1.1276$$

Noting that the average flow velocity is proportional to the overhead blade rotational velocity, the rpm of the helicopter blades on top of the mountain becomes

$$\dot{n} = kV_2 \quad \rightarrow \quad \frac{\dot{n}_{\text{mountain}}}{\dot{n}_{\text{sea}}} = \frac{V_{2,\text{mountain}}}{V_{2,\text{sea}}} \quad \rightarrow \quad \dot{n}_{\text{mountain}} = \frac{V_{2,\text{mountain}}}{V_{2,\text{sea}}} \dot{n}_{\text{sea}} = (1.1276)(550 \text{ rpm}) = 620.2 \text{ rpm} \cong \mathbf{620 \text{ rpm}}$$

Noting that  $P_1 = P_2 = P_{\text{atm}}$ ,  $V_1 \cong 0$ , the elevation effect are negligible, and the frictional effects are disregarded, the energy equation for the selected control volume reduces to

$$\dot{m} \left( \frac{P_1}{\rho} + \frac{V_1^2}{2} + gz_1 \right) + \dot{W}_{\text{pump,u}} = \dot{m} \left( \frac{P_2}{\rho} + \frac{V_2^2}{2} + gz_2 \right) + \dot{W}_{\text{turbine}} + \dot{E}_{\text{mech,loss}} \quad \rightarrow \quad \dot{W}_{\text{fan,u}} = \dot{m} \frac{V_2^2}{2}$$

$$\text{or } \dot{W}_{\text{fan,u}} = \dot{m} \frac{V_2^2}{2} = \rho AV_2 \frac{V_2^2}{2} = \rho A \frac{V_2^3}{2} = \frac{1}{2} \rho A \left( \sqrt{\frac{W}{\rho A}} \right)^3 = \frac{1}{2} \rho A \left( \frac{W}{\rho A} \right)^{1.5} = \frac{W^{1.5}}{2\sqrt{\rho A}}$$

Then the ratio of the required power input on top of the mountain to that at sea level becomes

$$\frac{\dot{W}_{\text{mountain fan,u}}}{\dot{W}_{\text{sea fan,u}}} = \frac{0.5W^{1.5} / \sqrt{\rho_{\text{mountain}}A}}{0.5W^{1.5} / \sqrt{\rho_{\text{sea}}A}} = \sqrt{\frac{\rho_{\text{sea}}}{\rho_{\text{mountain}}}} = \sqrt{\frac{1.18 \text{ kg/m}^3}{0.928 \text{ kg/m}^3}} = 1.128$$

Therefore, the required power input will increase by approximately **12.8%** on top of the mountain relative to the sea level.

**Discussion** Note that both the rpm and the required power input to the helicopter are inversely proportional to the square root of air density. Therefore, more power is required at higher elevations for the helicopter to operate because air is less dense, and more air must be forced by the blades into the downdraft.

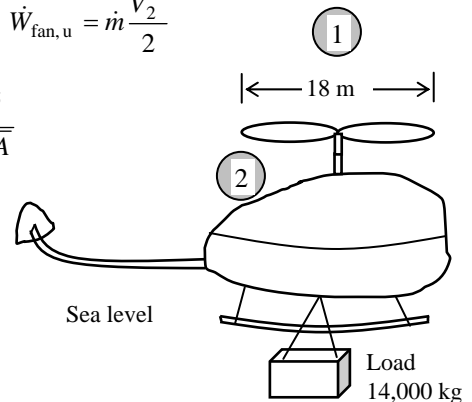

## 6-40

**Solution** Water flowing in a pipe is slowed down by a diffuser. The force exerted on the bolts due to water flow is to be determined.

**Assumptions** 1 The flow is steady and incompressible. 2 Frictional effects are negligible (so that the Bernoulli equation can be used). 3 The water is discharged to the atmosphere, and thus the gage pressure at the outlet is zero.

**Properties** We take the density of water to be  $1000 \text{ kg/m}^3$ .

**Analysis**

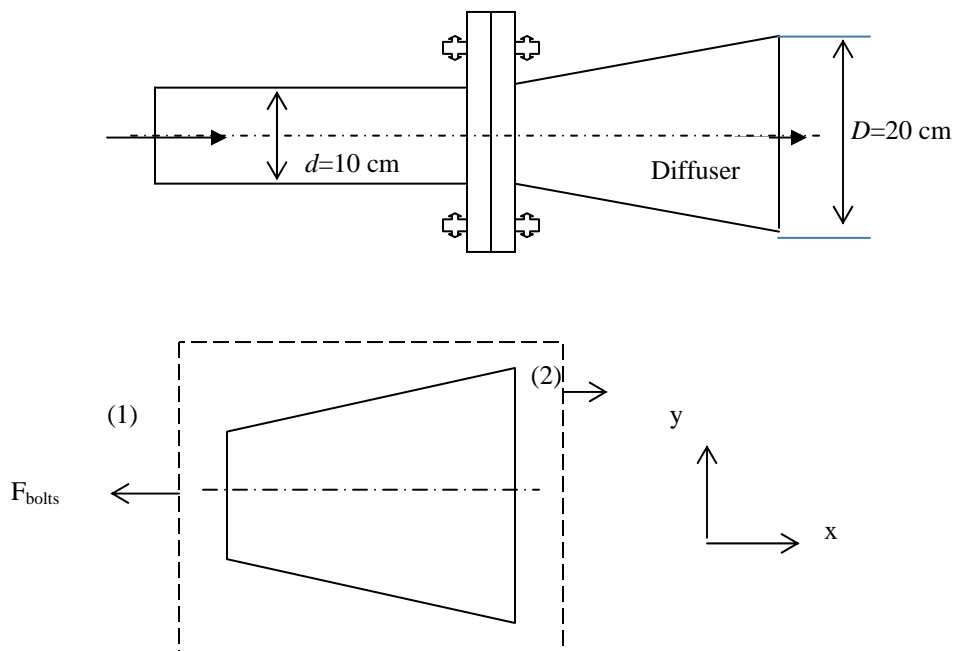

Writing Bernoulli equation between 1-2 ;

$$P_1 + \frac{1}{2} \rho V_1^2 + \gamma z_1 = P_2 + \frac{1}{2} \rho V_2^2 + \gamma z_2 + \text{negligible losses}$$

$$V_1 = \frac{0.1}{\pi \cdot 0.1^2 / 4} = 12.73 \text{ m/s}, \quad V_2 = \frac{0.1}{\pi \cdot 0.2^2 / 4} = 3.18 \text{ m/s}$$

$$P_1 = \frac{1}{2} \rho (V_2^2 - V_1^2) = \frac{1}{2} 1000 (12.73^2 - 3.18^2) = 75970 \text{ Pa}$$

Applying linear momentum to the CV gives;

$$\frac{\partial}{\partial t} \int_{cv} \vec{V} \rho dV + \int_{cs} \vec{V} \rho \vec{V} \cdot \vec{n} dA = \sum F_x \quad \text{and} \quad V_1 \rho (-V_1) A_1 + V_2 \rho (+V_2) A_2 = P_1 A_1 - F_{bolts}$$

$$\rho Q (V_2 - V_1) = P_1 A_1 - F_{bolts}$$

$$F_{bolts} = 75970 \pi \frac{0.1^2}{4} - 1000 \times 0.1 \times (3.18 - 12.73)$$

$$F_{bolts} = 1552 \leftarrow \text{fluid force on bolts } \mathbf{1552 \text{ N to right.}}$$

## 6-41

**Solution** The weight of a water tank is balanced by a counterweight. Water enters the tank horizontally and there is a hole at the bottom of the tank. The amount of mass that must be added to or removed from the counterweight to maintain balance when the hole at the bottom is opened is to be determined.

**Properties** We take the density of water to be  $1000 \text{ kg/m}^3$ .

**Analysis**

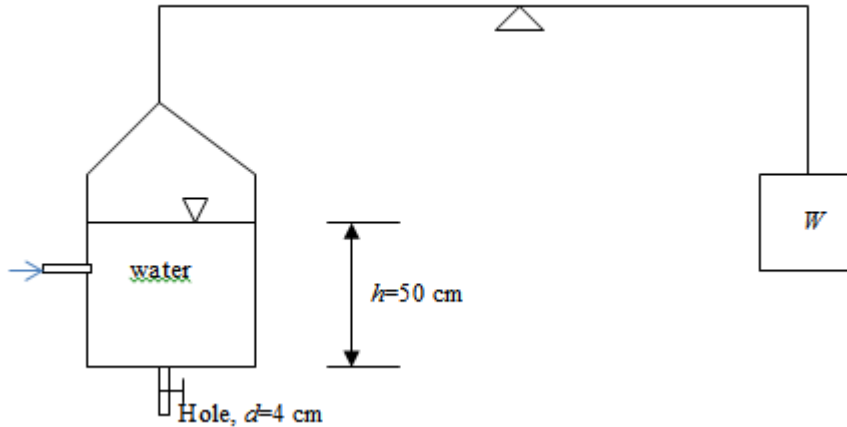

The flowrate from the hole, just after the valve is opened,

$$Q = CA_h \sqrt{2gh} = 0.90\pi \frac{0.04^2}{4} \sqrt{2 \times 9.81 \times 0.5} = 3.54 \times 10^{-3} \text{ m}^3 / \text{s}$$

$$V_{hole} = 0.90 \times \sqrt{2 \times 9.81 \times 0.5} = 2.82 \text{ m/s}$$

Reaction force due to momentum change

$$F = \rho Q V_h = 1000 \times 3.54 \times 10^{-3} \times 2.82 \approx 10 \text{ N}$$

Therefore the tank will sink just after the valve is opened, thus  $m = \frac{10}{9.81} \cong 1 \text{ kg}$  must be removed from the counterweight.

6-42



**Solution** A wind turbine with a given span diameter and efficiency is subjected to steady winds. The power generated and the horizontal force on the supporting mast of the turbine are to be determined.

**Assumptions** 1 The wind flow is steady and incompressible. 2 The efficiency of the turbine-generator is independent of wind speed. 3 The frictional effects are negligible, and thus none of the incoming kinetic energy is converted to thermal energy. 4 Wind flow is uniform and thus the momentum-flux correction factor is nearly unity,  $\beta \cong 1$ .

**Properties** The density of air is given to be  $1.25 \text{ kg/m}^3$ .

**Analysis** (a) The power potential of the wind is its kinetic energy, which is  $V^2/2$  per unit mass, and  $\dot{m}V^2/2$  for a given mass flow rate:

$$V_1 = (30 \text{ km/h}) \left( \frac{1 \text{ m/s}}{3.6 \text{ km/h}} \right) = 8.333 \text{ m/s}$$

$$\dot{m} = \rho_1 V_1 A_1 = \rho_1 V_1 \frac{\pi D^2}{4} = (1.25 \text{ kg/m}^3)(8.333 \text{ m/s}) \frac{\pi(60 \text{ m})^2}{4} = 29,452 \text{ kg/s}$$

$$\dot{W}_{\max} = \dot{m}ke_1 = \dot{m} \frac{V_1^2}{2} = (29,452 \text{ kg/s}) \frac{(8.333 \text{ m/s})^2}{2} \left( \frac{1 \text{ kN}}{1000 \text{ kg} \cdot \text{m/s}^2} \right) \left( \frac{1 \text{ kW}}{1 \text{ kN} \cdot \text{m/s}} \right) = 1023 \text{ kW}$$

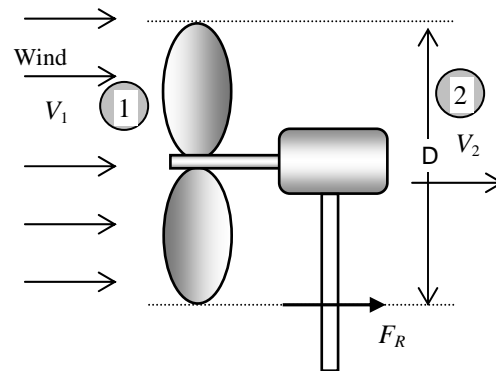

Then the actual power produced becomes

$$\dot{W}_{\text{act}} = \eta_{\text{wind turbine}} \dot{W}_{\max} = (0.32)(1023 \text{ kW}) = \mathbf{327 \text{ kW}}$$

(b) The frictional effects are assumed to be negligible, and thus the portion of incoming kinetic energy not converted to electric power leaves the wind turbine as outgoing kinetic energy. Therefore,

$$\dot{m}ke_2 = \dot{m}ke_1(1 - \eta_{\text{wind turbine}}) \rightarrow \dot{m} \frac{V_2^2}{2} = \dot{m} \frac{V_1^2}{2} (1 - \eta_{\text{wind turbine}})$$

or

$$V_2 = V_1 \sqrt{1 - \eta_{\text{wind turbine}}} = (8.333 \text{ m/s}) \sqrt{1 - 0.32} = 6.872 \text{ m/s}$$

We choose the control volume around the wind turbine such that the wind is normal to the control surface at the inlet and the outlet, and the entire control surface is at the atmospheric pressure. The momentum equation for steady flow is  $\sum \vec{F} = \sum_{\text{out}} \beta \dot{m} \vec{V} - \sum_{\text{in}} \beta \dot{m} \vec{V}$ . Writing it along the  $x$ -direction (without forgetting the negative sign for forces and velocities in the negative  $x$ -direction) and assuming the flow velocity through the turbine to be equal to the wind velocity give

$$F_R = \dot{m}V_2 - \dot{m}V_1 = \dot{m}(V_2 - V_1) = (29,452 \text{ kg/s})(6.872 - 8.333 \text{ m/s}) \left( \frac{1 \text{ kN}}{1000 \text{ kg} \cdot \text{m/s}^2} \right) = \mathbf{-43.0 \text{ kN}}$$

The negative sign indicates that the reaction force acts in the negative  $x$  direction, as expected.

**Discussion** This force acts on top of the tower where the wind turbine is installed, and the bending moment it generates at the bottom of the tower is obtained by multiplying this force by the tower height.

## 6-43

**Solution** Water enters a centrifugal pump axially at a specified rate and velocity, and leaves in the normal direction along the pump casing. The force acting on the shaft in the axial direction is to be determined.

**Properties** We take the density of water to be  $1000 \text{ kg/m}^3$ .

**Assumptions** **1** The flow is steady and incompressible. **2** The forces acting on the piping system in the horizontal direction are negligible. **3** The atmospheric pressure is disregarded since it acts on all surfaces.

**Analysis** We take the pump as the control volume, and the inlet direction of flow as the positive direction of  $x$  axis. The momentum equation for steady flow in the  $x$  (flow) direction reduces in this case to

$$\sum \vec{F} = \sum_{\text{out}} \beta \dot{m} \vec{V} - \sum_{\text{in}} \beta \dot{m} \vec{V} \quad \rightarrow \quad -F_{Rx} = -\dot{m}V_i \quad \rightarrow \quad F_{Rx} = \dot{m}V_i = \rho \dot{V}V_i$$

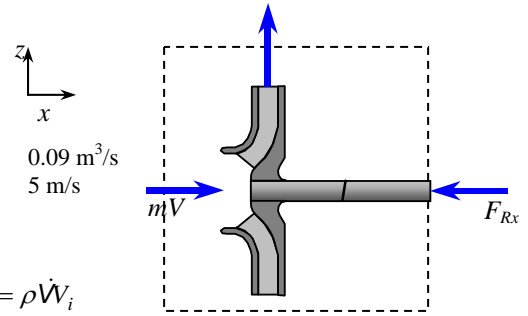

Note that the reaction force acts in the opposite direction to flow, and we should not forget the negative sign for forces and velocities in the negative  $x$ -direction. Substituting the given values,

$$F_{\text{brake}} = (1000 \text{ kg/m}^3)(0.09 \text{ m}^3/\text{s})(5 \text{ m/s}) \left( \frac{1 \text{ N}}{1 \text{ kg} \cdot \text{m/s}^2} \right) = \mathbf{450 \text{ N}}$$

**Discussion** To find the total force acting on the shaft, we also need to do a force balance for the vertical direction, and find the vertical component of the reaction force.



## 6-44

**Solution** A curved duct deflects a fluid. The horizontal force exerted on the duct by the fluid is to be determined.

**Assumptions** 1 The flow is steady and incompressible. 2 The momentum-flux correction factor for each inlet and outlet is given to account for frictional effects and the non-uniformity of the inlet and outlet velocity profiles.

**Properties** The density of the liquid is  $\rho = 998.2 \text{ kg/m}^3$ . Viscosity does not enter our analysis.

**Analysis** (a) We take the fluid within the duct as the control volume (see sketch), and designate the inlet by 1 and the outlet by 2. We also designate the horizontal coordinate by  $x$  (with the direction of flow as being the positive direction). Conservation of mass for this one-inlet one-outlet steady flow system is  $\dot{m} = \dot{m}_1 = \dot{m}_2$ . The mass flow rate is

$\dot{m} = \rho V_1 A_1 = \rho V_2 A_2$ , and the average speed at the outlet is thus

$V_2 = \frac{\dot{m}}{\rho A_2} = \frac{\rho V_1 A_1}{\rho A_2} = \frac{V_1 A_1}{A_2}$ . Since  $A_1 = A_2$  in this problem,  $V_2 = V_1$ . The momentum equation for steady flow in the  $x$ -

direction is  $\sum F_{x \text{ on CV}} = \sum_{\text{out}} \beta \dot{m} u - \sum_{\text{in}} \beta \dot{m} u$ , where  $u$  is the horizontal velocity component:  $u_1 = V_1$  and  $u_2 = -V_1$ . The total force on the control volume consists of pressure forces at the inlet and outlet plus the total of all forces (including pressure and viscous forces) acting on the control volume by the duct walls. Calling this force  $F_{x, \text{ duct on fluid}}$ , and assuming it to be in the positive  $x$ -direction, we write

$$P_{1, \text{gage}} A_1 + P_{2, \text{gage}} A_2 + F_{x, \text{ duct on fluid}} = \dot{m} \beta_2 (-V_1) - \dot{m} \beta_1 V_1$$

Note that we must be careful with the signs for forces (including pressure forces) and velocities. Solving for  $F_{x, \text{ duct on fluid}}$ , and plugging in  $\dot{m} = \rho V_1 A_1$ , we get

$$F_{x, \text{ duct on fluid}} = -(P_{1, \text{gage}} + P_{2, \text{gage}}) A_1 - \rho V_1^2 A_1 (\beta_1 + \beta_2)$$

Finally, the force exerted by the fluid on the duct is the negative of this, i.e.,

$$F_x = F_{x, \text{ fluid on duct}} = -F_{x, \text{ duct on fluid}} = (P_{1, \text{gage}} + P_{2, \text{gage}}) A_1 + \rho V_1^2 A_1 (\beta_1 + \beta_2)$$

(b) We verify our expression by plugging in the given values:

$$F_x = \left( 78470 \frac{\text{N}}{\text{m}^2} + 65230 \frac{\text{N}}{\text{m}^2} \right) (0.025 \text{ m}^2) + \left( 998.2 \frac{\text{kg}}{\text{m}^3} \right) \left( 10 \frac{\text{m}}{\text{s}} \right)^2 (0.025 \text{ m}^2) (1.01 + 1.03) \left( \frac{\text{N}}{\text{kg} \cdot \text{m/s}^2} \right)$$

$$= 8683.3 \text{ N} \cong \mathbf{8680 \text{ N}}$$

where we give the final answer to three significant digits in keeping with our convention.

**Discussion** The direction agrees with our intuition. The fluid is trying to push the duct to the right. A negative value for  $F_{x, \text{ fluid on duct}}$  indicates that the initially assumed direction was incorrect, but did not hinder our solution.

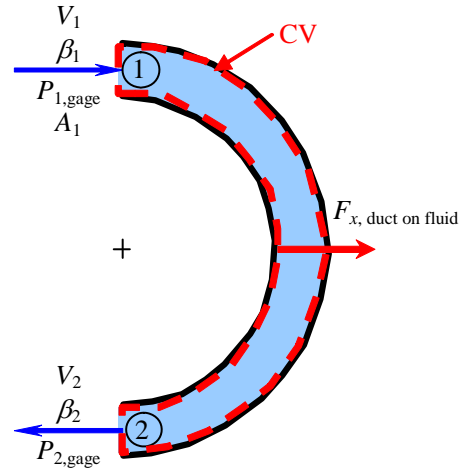

## 6-45

**Solution** A curved duct deflects a fluid. The horizontal force exerted on the duct by the fluid is to be determined.

**Assumptions** 1 The flow is steady and incompressible. 2 The momentum-flux correction factor for each inlet and outlet is given to account for frictional effects and the non-uniformity of the inlet and outlet velocity profiles.

**Properties** The density of the liquid is  $\rho = 998.2 \text{ kg/m}^3$ . Viscosity does not enter our analysis.

**Analysis** (a) We take the fluid within the duct as the control volume (see sketch), and designate the inlet by 1 and the outlet by 2. We also designate the horizontal coordinate by  $x$  (with the direction of flow as being the positive direction). Conservation of mass for this one-inlet one-outlet steady flow system is  $\dot{m} = \dot{m}_1 = \dot{m}_2$ . The mass flow rate is

$\dot{m} = \rho V_1 A_1 = \rho V_2 A_2$ , and the average speed at the outlet is thus

$$V_2 = \frac{\dot{m}}{\rho A_2} = \frac{\rho V_1 A_1}{\rho A_2} = \frac{V_1 A_1}{A_2}. \text{ The momentum equation for steady flow in the } x\text{-direction is } \sum F_{x \text{ on CV}} = \sum_{\text{out}} \beta \dot{m} u - \sum_{\text{in}} \beta \dot{m} u,$$

where  $u$  is the horizontal velocity component:  $u_1 = V_1$  and  $u_2 = -V_2$ . The total force on the control volume consists of pressure forces at the inlet and outlet plus the total of all forces (including pressure and viscous forces) acting on the control volume by the duct walls. Calling this force  $F_{x, \text{ duct on fluid}}$ , and assuming it to be in the positive  $x$ -direction, we write

$$P_{1, \text{gage}} A_1 + P_{2, \text{gage}} A_2 + F_{x, \text{ duct on fluid}} = \dot{m} \beta_2 (-V_2) - \dot{m} \beta_1 V_1$$

Note that we must be careful with the signs for forces (including pressure forces) and velocities. Solving for  $F_{x, \text{ duct on fluid}}$ ,

and plugging in  $\dot{m} = \rho V_1 A_1$  and  $V_2 = \frac{V_1 A_1}{A_2}$ , we get

$$F_{x, \text{ duct on fluid}} = -P_{1, \text{gage}} A_1 - P_{2, \text{gage}} A_2 - \rho V_1^2 A_1 \left( \beta_1 + \beta_2 \frac{A_1}{A_2} \right)$$

Finally, the force exerted by the fluid on the duct is the negative of this, i.e.,

$$F_x = F_{x, \text{ fluid on duct}} = -F_{x, \text{ duct on fluid}} = P_{1, \text{gage}} A_1 + P_{2, \text{gage}} A_2 + \rho V_1^2 A_1 \left( \beta_1 + \beta_2 \frac{A_1}{A_2} \right)$$

(b) We verify our expression by plugging in the given values:

$$\begin{aligned} F_x &= \left( 88340 \frac{\text{N}}{\text{m}^2} (0.025 \text{ m}^2) + 67480 \frac{\text{N}}{\text{m}^2} (0.015 \text{ m}^2) \right) \\ &\quad + \left( 998.2 \frac{\text{kg}}{\text{m}^3} \right) \left( 20 \frac{\text{m}}{\text{s}} \right)^2 (0.025 \text{ m}^2) \left( 1.02 + 1.04 \frac{0.025 \text{ m}^2}{0.015 \text{ m}^2} \right) \left( \frac{\text{N}}{\text{kg} \cdot \text{m/s}^2} \right) \\ &= 30704.5 \text{ N} \cong \mathbf{30,700 \text{ N to the right}} \end{aligned}$$

where we give the final answer to three significant digits in keeping with our convention.

**Discussion** The direction agrees with our intuition. The fluid is trying to push the duct to the right. A negative value for  $F_{x, \text{ fluid on duct}}$  indicates that the initially assumed direction was incorrect, but did not hinder our solution.

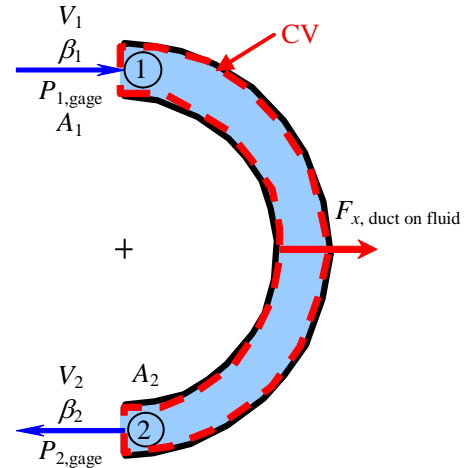

6-46

**Solution** The curved duct analysis of the previous problem is to be examined more closely. Namely, we are to explain how the pressure can actually *rise* from inlet to outlet.

**Analysis** The simple answer is that **when the area ratio is greater than 1, the duct acts as a diffuser**. From the Bernoulli approximation, we know that as the velocity decreases along the duct (since area increases), the pressure increases. Irreversibilities act counter to this, and cause the pressure to drop along the duct. For large enough area ratio, the diffuser effect “wins”. In this problem, the pressure changes from decreasing to increasing at an area ratio of around 1.3.

**Discussion** The curvature does not affect the fact that the duct acts like a diffuser – the area still increases. In fact, some diffusers are curved, e.g., centrifugal pumps and the draft tubes of hydroelectric turbines, as discussed in the turbomachinery chapter.

---

## 6-47

**Solution** A curved duct deflects a fluid. The horizontal force exerted on the duct by the fluid is to be determined.

**Assumptions** 1 The flow is steady and incompressible. 2 The momentum-flux correction factor for each inlet and outlet is given to account for frictional effects and the non-uniformity of the inlet and outlet velocity profiles.

**Properties** The density is given as  $\rho = 998.2 \text{ kg/m}^3$ . Viscosity does not enter our analysis.

**Analysis** (a) We take the fluid within the duct as the control volume (see sketch), and designate the inlet by 1 and the outlet by 2. We also designate the horizontal coordinate by  $x$  (with the direction of flow as being the positive direction). Conservation of mass for this one-inlet one-outlet steady flow system is  $\dot{m} = \dot{m}_1 = \dot{m}_2$ . The mass flow rate is  $\dot{m} = \rho V_1 A_1 = \rho V_2 A_2$ , and the

average speed at the outlet is thus  $V_2 = \frac{\dot{m}}{\rho A_2} = \frac{\rho V_1 A_1}{\rho A_2} = \frac{V_1 A_1}{A_2}$ . The momentum

equation for steady flow in the  $x$ -direction is  $\sum F_{x \text{ on CV}} = \sum_{\text{out}} \beta \dot{m} u - \sum_{\text{in}} \beta \dot{m} u$ , where  $u$  is the horizontal velocity component.

The total force on the control volume consists of pressure forces at the inlet and outlet plus the total of all forces (including pressure and viscous forces) acting on the control volume by the duct walls. Calling this force  $F_{x, \text{ duct on fluid}}$ , and assuming it to be in the positive  $x$ -direction, we write

$$P_{1,\text{gage}} A_1 - P_{2,\text{gage}} A_2 \cos \theta + F_{x, \text{ duct on fluid}} = \dot{m} \beta_2 V_2 \cos \theta - \dot{m} \beta_1 V_1$$

Note that we must be careful with the signs for forces (including pressure forces) and velocities. Solving for  $F_{x, \text{ duct on fluid}}$ , and plugging in  $\dot{m} = \rho V_1 A_1$ , we get

$$F_{x, \text{ duct on fluid}} = -P_{1,\text{gage}} A_1 + P_{2,\text{gage}} A_2 \cos \theta + \rho V_1 A_1 (\beta_2 V_2 \cos \theta - \beta_1 V_1)$$

$$\text{where } V_2 = \frac{V_1 A_1}{A_2}$$

Finally, the force exerted by the fluid on the duct is the negative of this, i.e.,

$$\boxed{F_x = F_{x, \text{ fluid on duct}} = -F_{x, \text{ duct on fluid}} = P_{1,\text{gage}} A_1 - P_{2,\text{gage}} A_2 \cos \theta + \rho V_1 A_1 (\beta_1 V_1 - \beta_2 V_2 \cos \theta)}$$

$$\text{where } V_2 = \frac{V_1 A_1}{A_2}$$

(b) We verify our expression by plugging in the given values:

$$V_2 = \frac{V_1 A_1}{A_2} = \frac{(6 \text{ m/s})(0.025 \text{ m}^2)}{0.050 \text{ m}^2} = 3 \text{ m/s}$$

and

$$\begin{aligned} F_x &= (78,470 \text{ N/m}^2)(0.025 \text{ m}^2) - (65,230 \text{ N/m}^2)(0.050 \text{ m}^2) \cos(135^\circ) \\ &\quad + (998.2 \text{ kg/m}^3)(6 \text{ m/s})(0.025 \text{ m}^2) \left[ (1.01)(6 \text{ m/s}) - (1.03)(3 \text{ m/s}) \cos(135^\circ) \right] \left( \frac{1 \text{ N}}{1 \text{ kg} \cdot \text{m/s}^2} \right) \\ &= 5502 \text{ N} \cong \mathbf{5500 \text{ N to the right}} \end{aligned}$$

where we give the final answer to three significant digits in keeping with our convention.

(c) We predict that **the force would maximize at  $\theta = 180^\circ$  because the water is turned completely around.**

**Discussion** The direction agrees with our intuition. The fluid is trying to push the duct to the right. A negative value for  $F_{x, \text{ fluid on duct}}$  indicates that the initially assumed direction was incorrect, but did not hinder our solution.

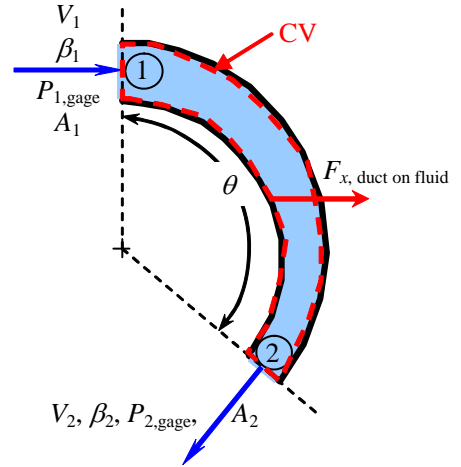

## 6-48

**Solution** A fireman's hose accelerates water from high pressure, low velocity to atmospheric pressure, high velocity at the nozzle exit plane. The horizontal force exerted on the duct by the water is to be determined.

**Assumptions** 1 The flow is steady and incompressible. 2 The momentum-flux correction factor for each inlet and outlet is given to account for frictional effects and the non-uniformity of the inlet and outlet velocity profiles.

**Properties** The density of the water is  $\rho = 998.2 \text{ kg/m}^3$ . Viscosity does not enter our analysis.

**Analysis** (a) We take the fluid within the duct as the control volume (see sketch), and designate the inlet by 1 and the outlet by 2. We also designate the horizontal coordinate by  $x$  (with the direction of flow as being the positive direction).

Conservation of mass for this one-inlet one-outlet steady flow system is  $\dot{m} = \dot{m}_1 = \dot{m}_2$ . The mass flow rate is

$\dot{m} = \rho V_1 A_1 = \rho V_2 A_2$ , and the average

speed at the outlet is thus

$$V_2 = \frac{\dot{m}}{\rho A_2} = \frac{\rho V_1 A_1}{\rho A_2} = \frac{V_1 A_1}{A_2}. \text{ The}$$

momentum equation for steady flow in the  $x$ -direction is

$$\sum F_{x \text{ on CV}} = \sum_{\text{out}} \beta \dot{m} u - \sum_{\text{in}} \beta \dot{m} u, \text{ where } u$$

is the horizontal velocity component:  $u_1 = V_1$  and  $u_2 = V_2$ . The total force on the control volume consists of pressure forces at the inlet and outlet plus the total of all forces (including pressure and viscous forces) acting on the control volume by the duct walls. Calling this force  $F_{x, \text{ duct on fluid}}$ , and assuming it to be in the positive  $x$ -direction, we write

$$P_{1, \text{gage}} A_1 - P_{2, \text{gage}} A_2 + F_{x, \text{ duct on fluid}} = \dot{m} \beta_2 (V_2) - \dot{m} \beta_1 V_1$$

Note that we must be careful with the signs for forces (including pressure forces) and velocities. Solving for  $F_{x, \text{ duct on fluid}}$ ,

and plugging in  $\dot{m} = \rho V_1 A_1$  and  $V_2 = \frac{V_1 A_1}{A_2}$ , we get

$$F_{x, \text{ duct on fluid}} = P_{2, \text{gage}} \frac{A_2}{A_1} A_1 - P_{1, \text{gage}} A_1 + \rho V_1^2 A_1 \left( \beta_2 \frac{A_1}{A_2} - \beta_1 \right)$$

Finally, the force exerted by the fluid on the duct is the negative of this, i.e.,

$$\begin{aligned} F_x = F_{x, \text{ fluid on duct}} = -F_{x, \text{ duct on fluid}} &= \left( P_{1, \text{gage}} - P_{2, \text{gage}} \frac{A_2}{A_1} \right) A_1 + \rho V_1^2 A_1 \left( \beta_1 - \beta_2 \frac{A_1}{A_2} \right) \\ &= A_1 \left[ \left( P_{1, \text{gage}} - P_{2, \text{gage}} \frac{A_2}{A_1} \right) + \rho V_1^2 \left( \beta_1 - \beta_2 \frac{A_1}{A_2} \right) \right] \end{aligned}$$

(b) We verify our expression by plugging in the given values:

$$\begin{aligned} F_x &= \frac{\pi}{4} (0.10 \text{ m})^2 \left[ \left( 123,000 \frac{\text{N}}{\text{m}^2} - 0 \frac{\text{N}}{\text{m}^2} \left( \frac{0.05}{0.10} \right)^2 \right) + \left( 998.2 \frac{\text{kg}}{\text{m}^3} \right) \left( 4 \frac{\text{m}}{\text{s}} \right)^2 \left( 1.03 - 1.02 \left( \frac{0.10}{0.050} \right)^2 \right) \left( \frac{\text{N}}{\text{kg} \cdot \text{m/s}^2} \right) \right] \\ &= 583.455 \text{ N} \cong \mathbf{583 \text{ N to the right}} \end{aligned}$$

where we give the final answer to three significant digits in keeping with our convention.

**Discussion** The direction agrees with our intuition. The fluid is trying to push the duct to the right. A negative value for  $F_{x, \text{ fluid on duct}}$  indicates that the initially assumed direction duct was incorrect, but did not hinder our solution.

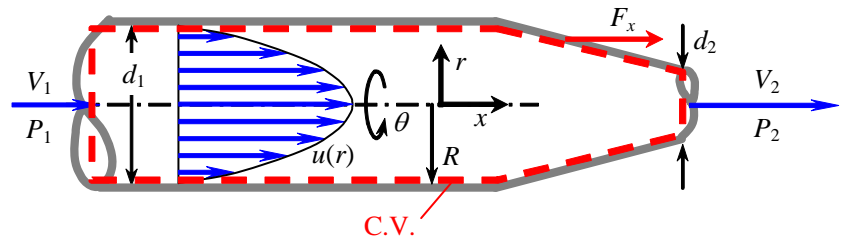

## 6-49

**Solution** A 90° reducer elbow deflects water downwards into a smaller diameter pipe. The resultant force exerted on the reducer by water is to be determined.

**Assumptions** 1 The flow is steady and incompressible. 2 Frictional effects are negligible in the calculation of the pressure drop (so that the Bernoulli equation can be used). 3 The weight of the elbow and the water in it is disregarded since the gravitational effects are negligible. 4 The momentum-flux correction factor for each inlet and outlet is given to be  $\beta = 1.04$ .

**Properties** We take the density of water to be  $1000 \text{ kg/m}^3$ .

**Analysis** We take the water within the elbow as the control volume (see sketch), and designate the inlet by 1 and the outlet by 2. We also designate the horizontal coordinate by  $x$  (with the direction of flow as being the positive direction) and the vertical coordinate by  $z$ . The continuity equation for this one-inlet one-outlet steady flow system is  $\dot{m} = \dot{m}_1 = \dot{m}_2$ . Noting that  $\dot{m} = \rho AV$ , the mass flow rate of water and its outlet velocity are

$$\dot{m} = \rho V_1 A_1 = \rho V_1 (\pi D_1^2 / 4) = (1000 \text{ kg/m}^3)(8 \text{ m/s})[\pi(0.25 \text{ m})^2 / 4] = 392.7 \text{ kg/s}$$

$$V_2 = \frac{\dot{m}}{\rho A_2} = \frac{\dot{m}}{\rho \pi D_2^2 / 4} = \frac{392.7 \text{ kg/s}}{(1000 \text{ kg/m}^3)[\pi(0.15 \text{ m})^2 / 4]} = 22.22 \text{ m/s}$$

The Bernoulli equation for a streamline going through the center of the reducing elbow is expressed as

$$\frac{P_1}{\rho g} + \frac{V_1^2}{2g} + z_1 = \frac{P_2}{\rho g} + \frac{V_2^2}{2g} + z_2 \quad \rightarrow \quad P_2 = P_1 + \rho g \left( \frac{V_1^2 - V_2^2}{2g} + z_1 - z_2 \right)$$

Using gage pressures and substituting, the gage pressure at the outlet becomes

$$P_2 = (300 \text{ kPa}) + (1000 \text{ kg/m}^3)(9.81 \text{ m/s}^2) \left( \frac{(8 \text{ m/s})^2 - (22.22 \text{ m/s})^2}{2(9.81 \text{ m/s}^2)} + 0.5 \right) \left( \frac{1 \text{ kN}}{1000 \text{ kg} \cdot \text{m/s}^2} \right) \left( \frac{1 \text{ kPa}}{1 \text{ kN/m}^2} \right) = 90.04 \text{ kPa}$$

The momentum equation for steady flow is  $\sum \vec{F} = \sum_{\text{out}} \beta \dot{m} \vec{V} - \sum_{\text{in}} \beta \dot{m} \vec{V}$ . We let the  $x$ - and  $z$ - components of the resultant

of the reaction forces exerted by the reducer elbow on water be  $F_{Rx}$  and  $F_{Rz}$ , and assume them to be in the positive directions. Noting that the atmospheric pressure acts from all directions and its effect cancels out, the momentum equations along the  $x$  and  $z$  axes become

$$F_{Rx} + P_{1,\text{gage}} A_1 = 0 - \beta_1 \dot{m} V_1$$

$$F_{Rz} + P_{2,\text{gage}} A_2 = \beta_2 \dot{m} (-V_2) - 0$$

Note that we should not forget the negative sign for forces (including pressure forces) and velocities in the negative  $x$  or  $z$  direction. Solving for  $F_{Rx}$  and  $F_{Rz}$ , and substituting the given values,

$$F_{Rx} = -\beta \dot{m} V_1 - P_{1,\text{gage}} A_1 = -1.04(392.7 \text{ kg/s})(8 \text{ m/s}) \left( \frac{1 \text{ kN}}{1000 \text{ kg} \cdot \text{m/s}^2} \right) - (300 \text{ kN/m}^2) \frac{\pi(0.25 \text{ m})^2}{4} = -17.99 \text{ kN}$$

$$F_{Rz} = -\beta \dot{m} V_2 + P_{2,\text{gage}} A_2 = -1.04(392.7 \text{ kg/s})(22.22 \text{ m/s}) \left( \frac{1 \text{ kN}}{1000 \text{ kg} \cdot \text{m/s}^2} \right) + (90.04 \text{ kN/m}^2) \frac{\pi(0.15 \text{ m})^2}{4} = -7.484 \text{ kN}$$

The force exerted by the water on the reducer elbow is the negative of this, i.e.,

$$\mathbf{F}_{x, \text{water on reducer}} = \mathbf{18.0 kN} \quad \text{and} \quad \mathbf{F}_{z, \text{water on reducer}} = \mathbf{7.48 kN}$$

The magnitude of the resultant force exerted by the water on the reducer, and its line of action from the  $+x$  direction are

$$F_R = \sqrt{F_{Rx}^2 + F_{Rz}^2} = \sqrt{(-17.99)^2 + (-7.484)^2} = \mathbf{19.5 kN}$$

$$\theta = \tan^{-1} \frac{F_{Rz}}{F_{Rx}} = \tan^{-1} \frac{-7.484}{-17.99} = \mathbf{22.6^\circ}$$

**Discussion** The direction agrees with our intuition. The water is trying to push the reducer to the right and up. Negative values for  $F_{Rx}$  and  $F_{Rz}$  indicate that the initially assumed directions were incorrect, but did not hinder our solution.

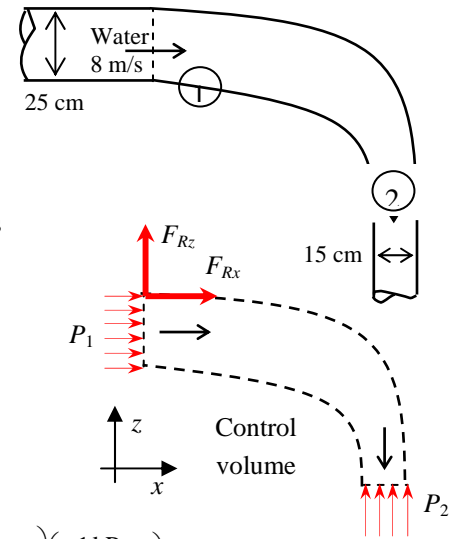

## 6-50

**Solution** The flow rate in a channel is controlled by a sluice gate by raising or lowering a vertical plate. A relation for the force acting on a sluice gate of width  $w$  for steady and uniform flow is to be developed.

**Assumptions** 1 The flow is steady, incompressible, frictionless, and uniform (and thus the Bernoulli equation is applicable.) 2 Wall shear forces at channel walls are negligible. 3 The channel is exposed to the atmosphere, and thus the pressure at free surfaces is the atmospheric pressure. 4 The flow is horizontal. 5 Water flow is nearly uniform and thus the momentum-flux correction factor can be taken to be unity,  $\beta \cong 1$ .

**Analysis** We take point 1 at the free surface of the upstream flow before the gate and point 2 at the free surface of the downstream flow after the gate. We also take the bottom surface of the channel as the reference level so that the elevations of points 1 and 2 are  $y_1$  and  $y_2$ , respectively. The application of the Bernoulli equation between points 1 and 2 gives

$$\frac{P_1}{\rho g} + \frac{V_1^2}{2g} + y_1 = \frac{P_2}{\rho g} + \frac{V_2^2}{2g} + y_2 \rightarrow V_2^2 - V_1^2 = 2g(y_1 - y_2) \quad (1)$$

The flow is assumed to be incompressible and thus the density is constant. Then the conservation of mass relation for this single stream steady flow device can be expressed as

$$\dot{V}_1 = \dot{V}_2 = \dot{V} \rightarrow A_1 V_1 = A_2 V_2 = \dot{V} \rightarrow V_1 = \frac{\dot{V}}{A_1} = \frac{\dot{V}}{w y_1} \quad \text{and} \quad V_2 = \frac{\dot{V}}{A_2} = \frac{\dot{V}}{w y_2} \quad (2)$$

Substituting into Eq. (1),

$$\left(\frac{\dot{V}}{w y_2}\right)^2 - \left(\frac{\dot{V}}{w y_1}\right)^2 = 2g(y_1 - y_2) \rightarrow \dot{V} = w \sqrt{\frac{2g(y_1 - y_2)}{1/y_2^2 - 1/y_1^2}} \rightarrow \dot{V} = w y_2 \sqrt{\frac{2g(y_1 - y_2)}{1 - y_2^2/y_1^2}} \quad (3)$$

Substituting Eq. (3) into Eqs. (2) gives the following relations for velocities,

$$V_1 = \frac{y_2}{y_1} \sqrt{\frac{2g(y_1 - y_2)}{1 - y_2^2/y_1^2}} \quad \text{and} \quad V_2 = \sqrt{\frac{2g(y_1 - y_2)}{1 - y_2^2/y_1^2}} \quad (4)$$

We choose the control volume as the water body surrounded by the vertical cross-sections of the upstream and downstream flows, free surfaces of water, the inner surface of the sluice gate, and the bottom surface of the channel. The momentum equation for steady flow is  $\sum \vec{F} = \sum_{\text{out}} \beta \dot{m} \vec{V} - \sum_{\text{in}} \beta \dot{m} \vec{V}$ . The force acting on the sluice gate  $F_{Rx}$  is horizontal since the wall

shear at the surfaces is negligible, and it is equal and opposite to the force applied on water by the sluice gate. Noting that the pressure force acting on a vertical surface is equal to the product of the pressure at the centroid of the surface and the surface area, the momentum equation along the  $x$  direction gives

$$-F_{Rx} + P_1 A_1 - P_2 A_2 = \dot{m} V_2 - \dot{m} V_1 \rightarrow -F_{Rx} + \left(\rho g \frac{y_1}{2}\right)(w y_1) - \left(\rho g \frac{y_2}{2}\right)(w y_2) = \dot{m}(V_2 - V_1)$$

Rearranging, the force acting on the sluice gate is determined to be

$$F_{Rx} = \dot{m}(V_1 - V_2) + \frac{w}{2} \rho g (y_1^2 - y_2^2) \quad (5)$$

where  $V_1$  and  $V_2$  are given in Eq. (4). Thus,

$$F_{Rx} = \dot{m} \left[ \frac{y_2}{y_1} \sqrt{\frac{2g(y_1 - y_2)}{1 - y_2^2/y_1^2}} - \sqrt{\frac{2g(y_1 - y_2)}{1 - y_2^2/y_1^2}} \right] + \frac{w}{2} \rho g (y_1^2 - y_2^2)$$

$$\text{or, simplifying, } F_{Rx} = \dot{m} \left( \frac{y_2}{y_1} - 1 \right) \sqrt{\frac{2g(y_1 - y_2)}{1 - y_2^2/y_1^2}} + \frac{w}{2} \rho g (y_1^2 - y_2^2).$$

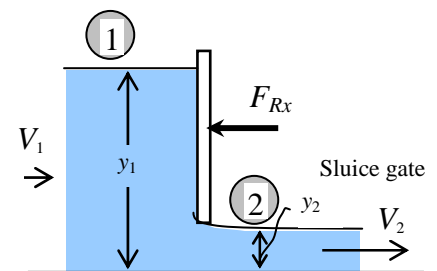

**Discussion** Note that for  $y_1 \gg y_2$ , Eq. (3) simplifies to  $\dot{V} = y_2 w \sqrt{2g y_1}$  or  $V_2 = \sqrt{2g y_1}$  which is the Toricelli equation for frictionless flow from a tank through a hole a distance  $y_1$  below the free surface.

---

## Angular Momentum Equation

---

**6-51C**

**Solution** We are to discuss how the angular momentum equation is obtained from the RTT.

**Analysis** The *angular momentum equation* is obtained by **replacing  $B$  in the Reynolds transport theorem by the total angular momentum  $\vec{H}_{sys}$ , and  $b$  by the angular momentum per unit mass  $\vec{r} \times \vec{V}$ .**

**Discussion** The RTT is a general equation that holds for any property  $B$ , either scalar or (as in this case) vector.

---

**6-52C**

**Solution** We are to express the angular momentum equation in scalar form about a specified axis.

**Analysis** The angular momentum equation about a given fixed axis in this case can be expressed in scalar form as  $\sum M = \sum_{out} r\dot{m}V - \sum_{in} r\dot{m}V$  where  $r$  is the moment arm,  $V$  is the magnitude of the radial velocity, and  $\dot{m}$  is the mass flow rate.

**Discussion** This is a simplification of the more general angular momentum equation (many terms have dropped out).

---

**6-53C**

**Solution** We are to express the angular momentum equation for a specific (restricted) control volume.

**Analysis** The angular momentum equation in this case is expressed as  $I\vec{\alpha} = -\vec{r} \times \dot{m}\vec{V}$  where  $\vec{\alpha}$  is the angular acceleration of the control volume, and  $\vec{r}$  is the vector from the axis of rotation to any point on the line of action of  $\vec{F}$ .

**Discussion** This is a simplification of the more general angular momentum equation (many terms have dropped out).

---

**6-54C**

**Solution** We are to compare the angular momentum of two rotating bodies

**Analysis** **No. The two bodies do not necessarily have the same angular momentum.** Two rigid bodies having the same mass and angular speed may have different angular momentums unless they also have the same moment of inertia  $I$ .

**Discussion** The reason why flywheels have most of their mass at the outermost radius, is to maximize the angular momentum.

---



## 6-55

**Solution** Water is pumped through a piping section. The moment acting on the elbow for the cases of downward and upward discharge is to be determined.

**Assumptions** **1** The flow is steady and incompressible. **2** The water is discharged to the atmosphere, and thus the gage pressure at the outlet is zero. **3** Effects of water falling down during upward discharge is disregarded. **4** Pipe outlet diameter is small compared to the moment arm, and thus we use average values of radius and velocity at the outlet.

**Properties** We take the density of water to be  $1000 \text{ kg/m}^3$ .

**Analysis** We take the entire pipe as the control volume, and designate the inlet by 1 and the outlet by 2. We also take the  $x$  and  $y$  coordinates as shown. The control volume and the reference frame are fixed. The conservation of mass equation for this one-inlet one-outlet steady flow system is  $\dot{m}_1 = \dot{m}_2 = \dot{m}$ , and  $V_1 = V_2 = V$  since  $A_c = \text{constant}$ . The mass flow rate and the weight of the horizontal section of the pipe are

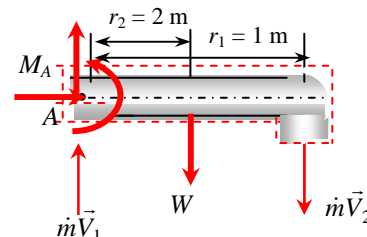

$$\dot{m} = \rho A_c V = (1000 \text{ kg/m}^3)[\pi(0.15 \text{ m})^2 / 4](7 \text{ m/s}) = 123.7 \text{ kg/s}$$

$$W = mg = (15 \text{ kg/m})(2 \text{ m})(9.81 \text{ m/s}^2) \left( \frac{1 \text{ N}}{1 \text{ kg} \cdot \text{m/s}^2} \right) = 294.3 \text{ N/m}$$

(a) **Downward discharge:** To determine the moment acting on the pipe at point A, we need to take the moment of all forces and momentum flows about that point. This is a steady and uniform flow problem, and all forces and momentum flows are in the same plane. Therefore, the angular momentum equation in this case can be expressed as  $\sum M = \sum_{\text{out}} r\dot{m}V - \sum_{\text{in}} r\dot{m}V$  where  $r$  is the moment arm, all moments in the counterclockwise direction are positive, and all in the clockwise direction are negative.

The free body diagram of the pipe section is given in the figure. Noting that the moments of all forces and momentum flows passing through point A are zero, the only force that will yield a moment about point A is the weight  $W$  of the horizontal pipe section, and the only momentum flow that will yield a moment is the outlet stream (both are negative since both moments are in the clockwise direction). Then the angular momentum equation about point A becomes

$$M_A - r_1 W = -r_2 \dot{m} V_2$$

Solving for  $M_A$  and substituting,

$$M_A = r_1 W - r_2 \dot{m} V_2 = (1 \text{ m})(294.3 \text{ N}) - (2 \text{ m})(123.7 \text{ kg/s})(7 \text{ m/s}) \left( \frac{1 \text{ N}}{1 \text{ kg} \cdot \text{m/s}^2} \right) = -1438 \text{ N} \cdot \text{m}$$

The negative sign indicates that the assumed direction for  $M_A$  is wrong, and should be reversed. Therefore, a moment of 70 N·m acts at the stem of the pipe in the clockwise direction.

(b) **Upward discharge:** The moment due to discharge stream is positive in this case, and the moment acting on the pipe at point A is

$$M_A = r_1 W + r_2 \dot{m} V_2 = (1 \text{ m})(294.3 \text{ N}) + (2 \text{ m})(123.7 \text{ kg/s})(7 \text{ m/s}) \left( \frac{1 \text{ N}}{1 \text{ kg} \cdot \text{m/s}^2} \right) = 2026 \text{ N} \cdot \text{m}$$

**Discussion** Note direction of discharge can make a big difference in the moments applied on a piping system. This problem also shows the importance of accounting for the moments of momentums of flow streams when performing evaluating the stresses in pipe materials at critical cross-sections.

## 6-56E

**Solution** A two-armed sprinkler is used to generate electric power. For a specified flow rate and rotational speed, the power produced is to be determined.

**Assumptions** 1 The flow is cyclically steady (i.e., steady from a frame of reference rotating with the sprinkler head). 2 The water is discharged to the atmosphere, and thus the gage pressure at the nozzle outlet is zero. 3 Generator losses and air drag of rotating components are neglected. 4 The nozzle diameter is small compared to the moment arm, and thus we use average values of radius and velocity at the outlet.

**Properties** We take the density of water to be  $62.4 \text{ lbf}/\text{ft}^3$ .

**Analysis** We take the disk that encloses the sprinkler arms as the control volume, which is a stationary control volume. The conservation of mass equation for this steady flow system is  $\dot{m}_1 = \dot{m}_2 = \dot{m}$ . Noting that the two nozzles are identical, we have  $\dot{m}_{\text{nozzle}} = \dot{m}/2$  or  $\dot{V}_{\text{nozzle}} = \dot{V}_{\text{total}}/2$  since the density of water is constant. The average jet outlet velocity relative to the nozzle is

$$V_{\text{jet}} = \frac{\dot{V}_{\text{nozzle}}}{A_{\text{jet}}} = \frac{2.5 \text{ gal/s}}{[\pi(0.5/12 \text{ ft})^2/4]} \left( \frac{1 \text{ ft}^3}{7.480 \text{ gal}} \right) = 245.1 \text{ ft/s}$$

The angular and tangential velocities of the nozzles are

$$\omega = 2\pi\dot{n} = 2\pi(180 \text{ rev/min}) \left( \frac{1 \text{ min}}{60 \text{ s}} \right) = 18.85 \text{ rad/s}$$

$$V_{\text{nozzle}} = r\omega = (2 \text{ ft})(18.85 \text{ rad/s}) = 37.70 \text{ ft/s}$$

The velocity of water jet relative to the control volume (or relative to a fixed location on earth) is

$$V_r = V_{\text{jet}} - V_{\text{nozzle}} = 245.1 - 37.70 = 207.4 \text{ ft/s}$$

The angular momentum equation can be expressed as  $\sum M = \sum_{\text{out}} r\dot{m}V - \sum_{\text{in}} r\dot{m}V$  where all moments in the counterclockwise direction are positive, and all in the clockwise direction are negative. Then the angular momentum equation about the axis of rotation becomes

$$-M_{\text{shaft}} = -2r\dot{m}_{\text{nozzle}}V_r \quad \text{or} \quad M_{\text{shaft}} = r\dot{m}_{\text{total}}V_r$$

Substituting, the torque transmitted through the shaft is determined to be

$$M_{\text{shaft}} = r\dot{m}_{\text{total}}V_r = (2 \text{ ft})(41.71 \text{ lbf}/\text{s})(207.4 \text{ ft/s}) \left( \frac{1 \text{ lbf}}{32.2 \text{ lbf} \cdot \text{ft}/\text{s}^2} \right) = 537.3 \text{ lbf} \cdot \text{ft}$$

since  $\dot{m}_{\text{total}} = \rho\dot{V}_{\text{total}} = (62.4 \text{ lbf}/\text{ft}^3)(5/7.480 \text{ ft}^3/\text{s}) = 41.71 \text{ lbf}/\text{s}$ . Then the power generated becomes

$$\dot{W} = 2\pi\dot{m}_{\text{shaft}}M_{\text{shaft}} = \omega M_{\text{shaft}} = (18.85 \text{ rad/s})(537.3 \text{ lbf} \cdot \text{ft}) \left( \frac{1 \text{ kW}}{737.56 \text{ lbf} \cdot \text{ft}/\text{s}} \right) = 13.7 \text{ kW}$$

Therefore, this sprinkler-type turbine has the potential to produce 13.7 kW of power.

**Discussion** This is, of course, the maximum possible power. The actual power generated would be much smaller than this due to all the irreversible losses that we have ignored in this analysis.

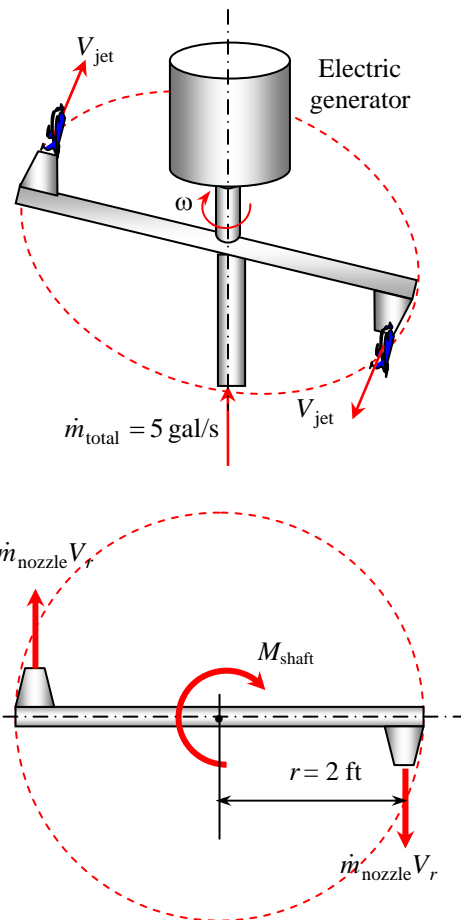

## 6-57E

**Solution** A two-armed sprinkler is used to generate electric power. For a specified flow rate and rotational speed, the moment acting on the rotating head when the head is stuck is to be determined.

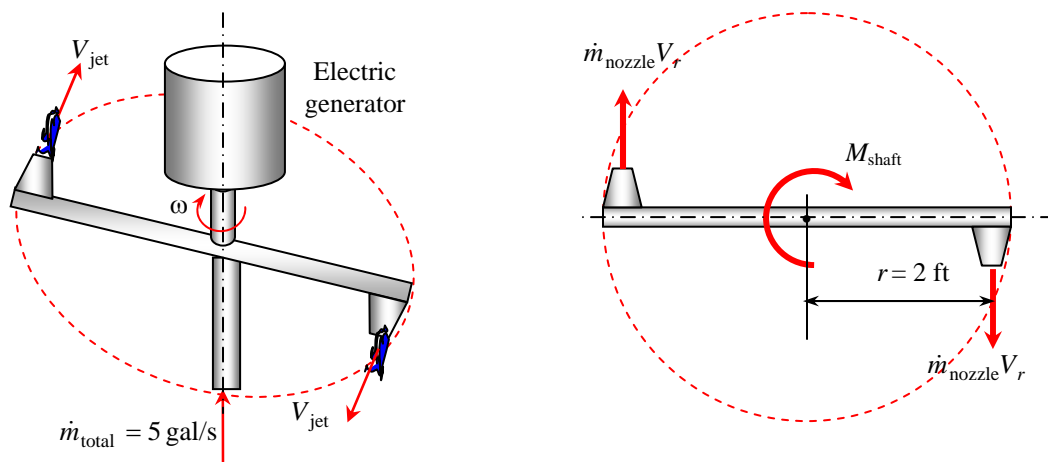

**Assumptions** 1 The flow is uniform and steady. 2 The water is discharged to the atmosphere, and thus the gage pressure at the nozzle outlet is zero. 3 The nozzle diameter is small compared to the moment arm, and thus we use average values of radius and velocity at the outlet.

**Properties** We take the density of water to be  $62.4 \text{ lbm/ft}^3$ .

**Analysis** We take the disk that encloses the sprinkler arms as the control volume, which is a stationary control volume. The conservation of mass equation for this steady flow system is  $\dot{m}_1 = \dot{m}_2 = \dot{m}$ . Noting that the two nozzles are identical, we have  $\dot{m}_{\text{nozzle}} = \dot{m} / 2$  or  $\dot{V}_{\text{nozzle}} = \dot{V}_{\text{total}} / 2$  since the density of water is constant. The average jet outlet velocity relative to the nozzle is

$$V_{\text{jet}} = \frac{\dot{V}_{\text{nozzle}}}{A_{\text{jet}}} = \frac{2.5 \text{ gal/s}}{[\pi(0.5/12 \text{ ft})^2 / 4]} \left( \frac{1 \text{ ft}^3}{7.480 \text{ gal}} \right) = 245.1 \text{ ft/s}$$

The angular momentum equation can be expressed as  $\sum M = \sum_{\text{out}} r\dot{m}V - \sum_{\text{in}} r\dot{m}V$  where all moments in the counterclockwise direction are positive, and all in the clockwise direction are negative. Then the angular momentum equation about the axis of rotation becomes

$$-M_{\text{shaft}} = -2r\dot{m}_{\text{nozzle}}V_{\text{jet}} \quad \text{or} \quad M_{\text{shaft}} = r\dot{m}_{\text{total}}V_{\text{jet}}$$

Substituting, the torque transmitted through the shaft is determined to be

$$M_{\text{shaft}} = r\dot{m}_{\text{total}}V_{\text{jet}} = (2 \text{ ft})(41.71 \text{ lbm/s})(245.1 \text{ ft/s}) \left( \frac{1 \text{ lbf}}{32.2 \text{ lbm} \cdot \text{ft/s}^2} \right) = \mathbf{635 \text{ lbf} \cdot \text{ft}}$$

since  $\dot{m}_{\text{total}} = \rho\dot{V}_{\text{total}} = (62.4 \text{ lbm/ft}^3)(5/7.480 \text{ ft}^3/\text{s}) = 41.71 \text{ lbm/s}$ .

**Discussion** When the sprinkler is stuck and thus the angular velocity is zero, the torque developed is maximum since  $V_{\text{nozzle}} = 0$  and thus  $V_r = V_{\text{jet}} = 245.1 \text{ ft/s}$ , giving  $M_{\text{shaft,max}} = 635 \text{ lbf} \cdot \text{ft}$ . But the power generated is zero in this case since the shaft does not rotate.

## 6-58

**Solution** A centrifugal pump is used to supply water at a specified rate and angular speed. The minimum power consumption of the pump is to be determined.

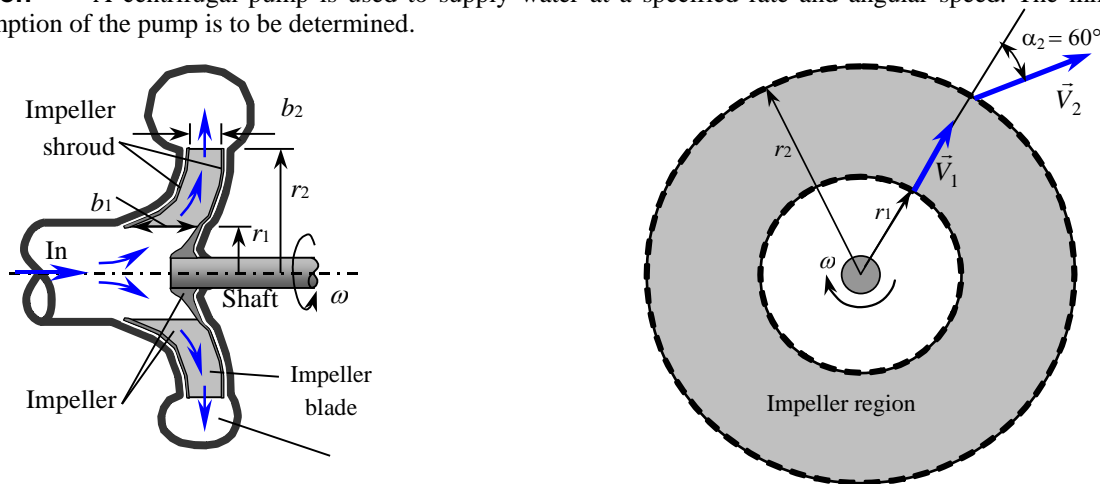

**Assumptions** 1 The flow is steady in the mean. 2 Irreversible losses are negligible.

**Properties** We take the density of water to be  $1000 \text{ kg/m}^3$ .

**Analysis** We take the impeller region as the control volume. The normal velocity components at the inlet and the outlet are

$$V_{1,n} = \frac{\dot{V}}{2\pi r_1 b_1} = \frac{0.15 \text{ m}^3/\text{s}}{2\pi((0.13/2) \text{ m})(0.080 \text{ m})} = 4.5910 \text{ m/s}$$

$$V_{2,n} = \frac{\dot{V}}{2\pi r_2 b_2} = \frac{0.15 \text{ m}^3/\text{s}}{2\pi((0.30/2) \text{ m})(0.035 \text{ m})} = 4.54728 \text{ m/s}$$

The tangential components of absolute velocity are:

$$\alpha_1 = 0^\circ: \quad V_{1,t} = V_{1,n} \tan \alpha_1 = 0$$

$$\alpha_2 = 60^\circ: \quad V_{2,t} = V_{2,n} \tan \alpha_2 = (4.54728 \text{ m/s}) \tan 60^\circ = 7.87613 \text{ m/s}$$

The angular velocity of the propeller is

$$\omega = 2\pi i = 2\pi(1200 \text{ rev/min})\left(\frac{1 \text{ min}}{60 \text{ s}}\right) = 125.7 \text{ rad/s}$$

$$\dot{m} = \rho \dot{V} = (1000 \text{ kg/m}^3)(0.15 \text{ m}^3/\text{s}) = 150 \text{ kg/s}$$

Normal velocity components  $V_{1,n}$  and  $V_{2,n}$  as well pressure acting on the inner and outer circumferential areas pass through the shaft center, and thus they do not contribute to torque. Only the tangential velocity components contribute to torque, and the application of the angular momentum equation gives

$$T_{\text{shaft}} = \dot{m}(r_2 V_{2,t} - r_1 V_{1,t}) = (150 \text{ kg/s})[(0.30 \text{ m})(7.87613 \text{ m/s}) - 0] \left(\frac{1 \text{ kN}}{1000 \text{ kg} \cdot \text{m/s}^2}\right) = 0.354426 \text{ kN} \cdot \text{m}$$

Then the shaft power becomes

$$\dot{W} = \omega T_{\text{shaft}} = (125.7 \text{ rad/s})(0.354426 \text{ kN} \cdot \text{m}) \left(\frac{1 \text{ kW}}{1 \text{ kN} \cdot \text{m/s}}\right) = 44.5513 \text{ kW} \approx \mathbf{44.6 \text{ kW}}$$

**Discussion** Note that the irreversible losses are not considered in analysis. In reality, the required power input will be larger.

## 6-59

**Solution** A centrifugal blower is used to deliver atmospheric air. For a given angular speed and power input, the volume flow rate of air is to be determined.

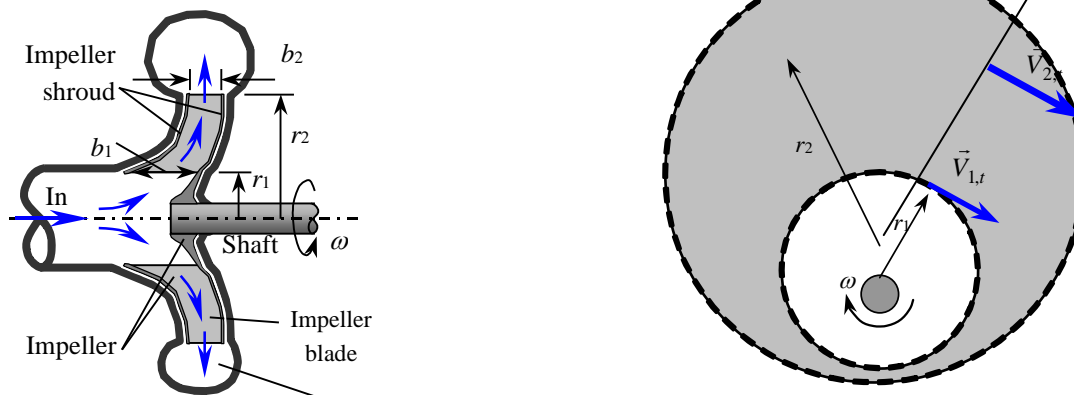

**Assumptions** 1 The flow is steady in the mean. 2 Irreversible losses are negligible. 3 The tangential components of air velocity at the inlet and the outlet are said to be equal to the impeller velocity at respective locations.

**Properties** The gas constant of air is  $0.287 \text{ kPa}\cdot\text{m}^3/\text{kg}\cdot\text{K}$ . The density of air at  $20^\circ\text{C}$  and  $95 \text{ kPa}$  is

$$\rho = \frac{P}{RT} = \frac{95 \text{ kPa}}{(0.287 \text{ kPa}\cdot\text{m}^3/\text{kg}\cdot\text{K})(293 \text{ K})} = 1.130 \text{ kg/m}^3$$

**Analysis** In the idealized case of the tangential fluid velocity being equal to the blade angular velocity both at the inlet and the outlet, we have  $V_{1,t} = \omega r_1$  and  $V_{2,t} = \omega r_2$ , and the torque is expressed as

$$T_{\text{shaft}} = \dot{m}(r_2 V_{2,t} - r_1 V_{1,t}) = \dot{m}\omega(r_2^2 - r_1^2) = \rho \dot{V}\omega(r_2^2 - r_1^2)$$

where the angular velocity is

$$\omega = 2\pi i = 2\pi(900 \text{ rev/min})\left(\frac{1 \text{ min}}{60 \text{ s}}\right) = 94.25 \text{ rad/s}$$

Then the shaft power becomes

$$\dot{W}_{\text{shaft}} = \omega T_{\text{shaft}} = \rho \dot{V}\omega^2(r_2^2 - r_1^2)$$

Solving for  $\dot{V}$  and substituting, the volume flow rate of air is determined to

$$\dot{V} = \frac{\dot{W}_{\text{shaft}}}{\rho\omega^2(r_2^2 - r_1^2)} = \frac{120 \text{ N}\cdot\text{m/s}}{(1.130 \text{ kg/m}^3)(94.25 \text{ rad/s})^2[(0.30 \text{ m})^2 - (0.18 \text{ m})^2]}\left(\frac{1 \text{ kg}\cdot\text{m/s}^2}{1 \text{ N}}\right) = \mathbf{0.2075 \text{ m}^3/\text{s}}$$

The normal velocity components at the inlet and the outlet are

$$V_{1,n} = \frac{\dot{V}}{2\pi r_1 b_1} = \frac{0.2075 \text{ m}^3/\text{s}}{2\pi(0.18 \text{ m})(0.061 \text{ m})} = \mathbf{3.01 \text{ m/s}}$$

$$V_{2,n} = \frac{\dot{V}}{2\pi r_2 b_2} = \frac{0.2075 \text{ m}^3/\text{s}}{2\pi(0.30 \text{ m})(0.034 \text{ m})} = \mathbf{3.24 \text{ m/s}}$$

**Discussion** Note that the irreversible losses are not considered in this analysis. In reality, the flow rate and the normal components of velocities will be smaller.

## 6-60

**Solution** Water enters a two-armed sprinkler vertically, and leaves the nozzles horizontally. For a specified flow rate, the rate of rotation of the sprinkler and the torque required to prevent the sprinkler from rotating are to be determined.

**Assumptions** 1 The flow is uniform and cyclically steady (i.e., steady from a frame of reference rotating with the sprinkler head). 2 The water is discharged to the atmosphere, and thus the gage pressure at the nozzle outlet is zero. 3 Frictional effects and air drag of rotating components are neglected. 4 The nozzle diameter is small compared to the moment arm, and thus we use average values of radius and velocity at the outlet.

**Properties** We take the density of water to be  $1000 \text{ kg/m}^3 = 1 \text{ kg/L}$ .

**Analysis** We take the disk that encloses the sprinkler arms as the control volume, which is a stationary control volume. The conservation of mass equation for this symmetrical steady flow system is  $\dot{m}_1 + \dot{m}_2 = \dot{m}$  or  $\dot{V}_{\text{jet},1} + \dot{V}_{\text{jet},2} = \dot{V}_{\text{total}}$  since the density of water is constant. Both jets are at the same elevation and pressure, and the frictional effects are said to be negligible. Also, the head losses in each arm are equal, so that mass flow rates in each nozzle are identical. Then,

$$V_{\text{jet},r,1} = \frac{\dot{V}_{\text{total}}/2}{A_{\text{jet},1}} = \frac{(35/2) \text{ L/s}}{3 \times 10^{-4} \text{ m}^2} \left( \frac{1 \text{ m}^3}{1000 \text{ L}} \right) = 58.33 \text{ m/s}$$

$$V_{\text{jet},r,2} = \frac{\dot{V}_{\text{total}}/2}{A_{\text{jet},2}} = \frac{(35/2) \text{ L/s}}{5 \times 10^{-4} \text{ m}^2} \left( \frac{1 \text{ m}^3}{1000 \text{ L}} \right) = 35.00 \text{ m/s}$$

Noting that  $V_{\text{nozzle}} = \omega r = 2\pi ir$  and assuming the sprinkler to rotate in the clock-wise direction, the absolute water jet speeds in the tangential direction can be expressed as

$$V_{\text{jet},1} = V_{\text{jet},r,1} + V_{\text{nozzle},1} = V_{\text{jet},r,1} + \omega r_1 \quad (\text{Nozzle and water jet move in the same direction}).$$

$$V_{\text{jet},2} = V_{\text{jet},r,2} - V_{\text{nozzle},2} = V_{\text{jet},r,2} - \omega r_2 \quad (\text{Nozzle and water jet move in opposite directions}).$$

The angular momentum equation about the axis of rotation can be expressed as  $\sum M = \sum_{\text{out}} r m V - \sum_{\text{in}} r m V$  where  $r$  is the average moment arm,  $V$  is the average absolute speed (relative to an inertial reference frame), all moments in the counterclockwise direction are positive, and all moments in the clockwise direction are negative. Momentum flows in the clockwise direction are also negative. Then the angular momentum equation becomes

$$T_{\text{shaft}} = -r_1 \dot{m}_{\text{jet},1} V_{\text{jet},1} + r_2 \dot{m}_{\text{jet},2} V_{\text{jet},2} \rightarrow T_{\text{shaft}} = -r_1 \dot{m}_{\text{jet},1} (V_{\text{jet},r,1} + \omega r_1) + r_2 \dot{m}_{\text{jet},2} (V_{\text{jet},r,2} - \omega r_2)$$

Noting that  $\dot{m}_{\text{jet}} = \rho A V_{\text{jet},r}$  and rearranging,

$$\dot{m}_{\text{jet},1} = \rho \dot{V} = 1000 \times 17.5 / 1000 = 17.5 \text{ kg/s} = \dot{m}_{\text{jet},2}$$

(a) In the case of free spin with no frictional effects, we have  $T_{\text{shaft}} = 0$  and thus  $0 = (r_2 A_2 - r_1 A_1) V_{\text{jet},r} - (r_1^2 A_1 + r_2^2 A_2) \omega$ .

Then angular speed and the rate of rotation of sprinkler head becomes

$$0 = -0.5 \times 17.5 \times (58.33 + 0.5\omega) + 0.35 \times 17.5 \times (35 - 0.35\omega)$$

$$\omega = -45.41 \text{ rad/s} = \mathbf{434 \text{ rpm}} \quad (\text{counterclockwise})$$

(b) When the sprinkler is prevented from rotating, we have  $\omega = 0$ . Then the required torque becomes

$$T_{\text{shaft}} = -r_1 \dot{m}_{\text{jet},1} V_{\text{jet},r,1} + r_2 \dot{m}_{\text{jet},2} V_{\text{jet},r,2} = -0.5 \times 17.5 \times 58.33 + 0.35 \times 17.5 \times 35 = \mathbf{-296 \text{ N} \cdot \text{m}}$$

**Discussion** The rate of rotation determined in (a) will be lower in reality because of frictional effects and air drag.

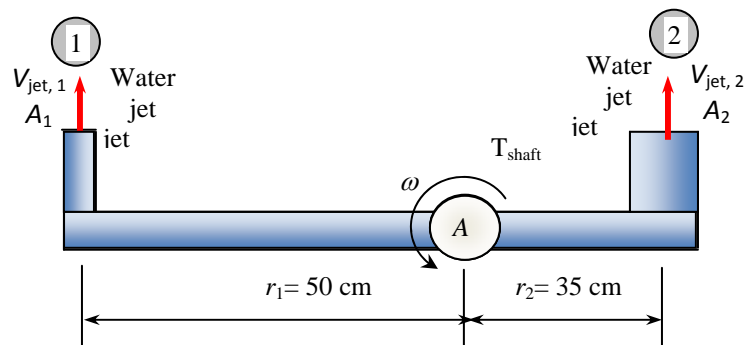

## 6-61

**Solution** Water enters a two-armed sprinkler vertically, and leaves the nozzles horizontally. For a specified flow rate, the rate of rotation of the sprinkler and the torque required to prevent the sprinkler from rotating are to be determined.

**Assumptions** 1 The flow is uniform and cyclically steady (i.e., steady from a frame of reference rotating with the sprinkler head). 2 The water is discharged to the atmosphere, and thus the gage pressure at the nozzle outlet is zero. 3 Frictional effects and air drag of rotating components are neglected. 4 The nozzle diameter is small compared to the moment arm, and thus we use average values of radius and velocity at the outlet.

**Properties** We take the density of water to be  $1000 \text{ kg/m}^3 = 1 \text{ kg/L}$ .

**Analysis** We take the disk that encloses the sprinkler arms as the control volume, which is a stationary control volume. The conservation of mass equation for this symmetrical steady flow system is  $\dot{m}_1 + \dot{m}_2 = \dot{m}$  or  $\dot{V}_{\text{jet},1} + \dot{V}_{\text{jet},2} = \dot{V}_{\text{total}}$  since the density of water is constant. Both jets are at the same elevation and pressure, and the frictional effects are said to be negligible. Also, the head losses in each arm are equal, so that mass flow rates in each nozzle are identical. Then,

$$V_{\text{jet},r,1} = \frac{\dot{V}_{\text{total}}/2}{A_{\text{jet},1}} = \frac{(50/2) \text{ L/s}}{3 \times 10^{-4} \text{ m}^2} \left( \frac{1 \text{ m}^3}{1000 \text{ L}} \right) = 83.33 \text{ m/s}$$

$$V_{\text{jet},r,2} = \frac{\dot{V}_{\text{total}}/2}{A_{\text{jet},2}} = \frac{(50/2) \text{ L/s}}{5 \times 10^{-4} \text{ m}^2} \left( \frac{1 \text{ m}^3}{1000 \text{ L}} \right) = 50.0 \text{ m/s}$$

Noting that  $V_{\text{nozzle}} = \omega r = 2\pi \dot{m} r$  and assuming the sprinkler to rotate in the clock-wise direction, the absolute water jet speeds in the tangential direction can be expressed as

$$V_{\text{jet},1} = V_{\text{jet},r,1} + V_{\text{nozzle},1} = V_{\text{jet},r,1} + \omega r_1 \quad (\text{Nozzle and water jet move in the same direction}).$$

$$V_{\text{jet},2} = V_{\text{jet},r,2} - V_{\text{nozzle},2} = V_{\text{jet},r,2} - \omega r_2 \quad (\text{Nozzle and water jet move in opposite directions}).$$

The angular momentum equation about the axis of rotation can be expressed as  $\sum M = \sum_{\text{out}} r\dot{m}V - \sum_{\text{in}} r\dot{m}V$  where  $r$  is the

average moment arm,  $V$  is the average absolute speed (relative to an inertial reference frame), all moments in the counterclockwise direction are positive, and all moments in the clockwise direction are negative. Momentum flows in the clockwise direction are also negative. Then the angular momentum equation becomes

$$T_{\text{shaft}} = -r_1 \dot{m}_{\text{jet},1} V_{\text{jet},1} + r_2 \dot{m}_{\text{jet},2} V_{\text{jet},2} \rightarrow T_{\text{shaft}} = -r_1 \dot{m}_{\text{jet},1} (V_{\text{jet},r,1} + \omega r_1) + r_2 \dot{m}_{\text{jet},2} (V_{\text{jet},r,2} - \omega r_2)$$

Noting that  $\dot{m}_{\text{jet}} = \rho A V_{\text{jet},r}$  and rearranging,

$$\dot{m}_{\text{jet},1} = \rho \dot{V} = 1000 \times 25 / 1000 = 25 \text{ kg/s} = \dot{m}_{\text{jet},2}$$

(a) In the case of free spin with no frictional effects, we have  $T_{\text{shaft}} = 0$  and thus  $0 = (r_2 A_2 - r_1 A_1) V_{\text{jet},r} - (r_1^2 A_1 + r_2^2 A_2) \omega$ .

Then angular speed and the rate of rotation of sprinkler head becomes

$$0 = -0.5 \times 25 \times (83.33 + 0.5\omega) + 0.35 \times 25 \times (50 - 0.35\omega)$$

$$\omega = -64.89 \text{ rad/s} = \mathbf{620 \text{ rpm}} \quad (\text{counterclockwise})$$

(b) When the sprinkler is prevented from rotating, we have  $\omega = 0$ . Then the required torque becomes

$$T_{\text{shaft}} = -r_1 \dot{m}_{\text{jet},1} V_{\text{jet},r,1} + r_2 \dot{m}_{\text{jet},2} V_{\text{jet},r,2} = -0.5 \times 25 \times 83.33 + 0.35 \times 25 \times 50 = \mathbf{-604 \text{ N} \cdot \text{m}}$$

**Discussion** The rate of rotation determined in (a) will be lower in reality because of frictional effects and air drag.

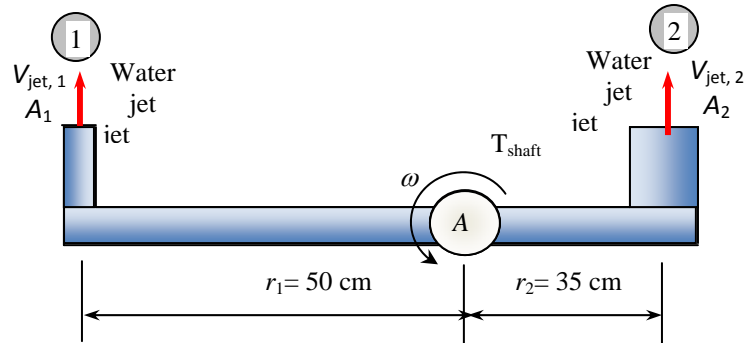



## 6-62

**Solution** A centrifugal blower is used to deliver atmospheric air at a specified rate and angular speed. The minimum power consumption of the blower is to be determined.

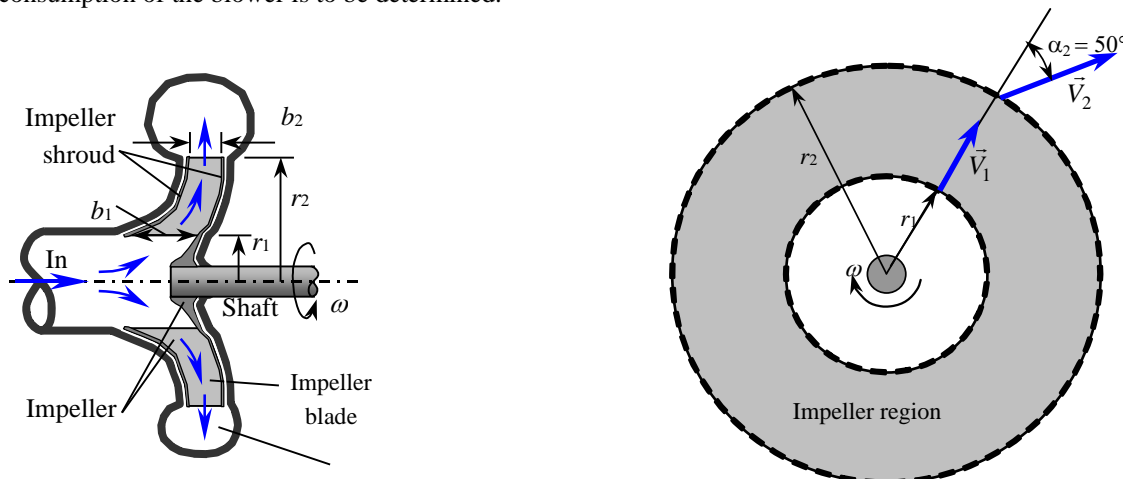

**Assumptions** 1 The flow is steady in the mean. 2 Irreversible losses are negligible.

**Properties** The density of air is given to be  $1.25 \text{ kg/m}^3$ .

**Analysis** We take the impeller region as the control volume. The normal velocity components at the inlet and the outlet are

$$V_{1,n} = \frac{\dot{V}}{2\pi r_1 b_1} = \frac{0.70 \text{ m}^3/\text{s}}{2\pi(0.20 \text{ m})(0.082 \text{ m})} = 6.793 \text{ m/s}$$

$$V_{2,n} = \frac{\dot{V}}{2\pi r_2 b_2} = \frac{0.70 \text{ m}^3/\text{s}}{2\pi(0.45 \text{ m})(0.056 \text{ m})} = 4.421 \text{ m/s}$$

The tangential components of absolute velocity are:

$$\alpha_1 = 0^\circ: \quad V_{1,t} = V_{1,n} \tan \alpha_1 = 0$$

$$\alpha_2 = 60^\circ: \quad V_{2,t} = V_{2,n} \tan \alpha_2 = (4.421 \text{ m/s}) \tan 50^\circ = 5.269 \text{ m/s}$$

The angular velocity of the propeller is

$$\omega = 2\pi i = 2\pi(700 \text{ rev/min}) \left( \frac{1 \text{ min}}{60 \text{ s}} \right) = 73.30 \text{ rad/s}$$

$$\dot{m} = \rho \dot{V} = (1.25 \text{ kg/m}^3)(0.7 \text{ m}^3/\text{s}) = 0.875 \text{ kg/s}$$

Normal velocity components  $V_{1,n}$  and  $V_{2,n}$  as well pressure acting on the inner and outer circumferential areas pass through the shaft center, and thus they do not contribute to torque. Only the tangential velocity components contribute to torque, and the application of the angular momentum equation gives

$$T_{\text{shaft}} = \dot{m}(r_2 V_{2,t} - r_1 V_{1,t}) = (0.875 \text{ kg/s})[(0.45 \text{ m})(5.269 \text{ m/s}) - 0] \left( \frac{1 \text{ N}}{1 \text{ kg} \cdot \text{m/s}^2} \right) = 2.075 \text{ N} \cdot \text{m}$$

Then the shaft power becomes

$$\dot{W} = \omega T_{\text{shaft}} = (73.30 \text{ rad/s})(2.075 \text{ N} \cdot \text{m}) \left( \frac{1 \text{ W}}{1 \text{ N} \cdot \text{m/s}} \right) = \mathbf{152 \text{ W}}$$

**Discussion** The actual required shaft power is greater than this, due to the friction and other irreversibilities that we have neglected in our analysis. Nevertheless, this is a good first approximation.



6-63



**Solution** The previous problem is reconsidered. The effect of discharge angle  $\alpha_2$  on the minimum power input requirements as  $\alpha_2$  varies from  $0^\circ$  to  $85^\circ$  in increments of  $5^\circ$  is to be investigated.

**Analysis** The EES Equations window is printed below, followed by the tabulated and plotted results.

```
rho=1.25 "kg/m3"
r1=0.20 "m"
b1=0.082 "m"
r2=0.45 "m"
b2=0.056 "m"
V_dot=0.70 "m3/s"
V1n=V_dot/(2*pi*r1*b1) "m/s"
V2n=V_dot/(2*pi*r2*b2) "m/s"
Alpha1=0
V1t=V1n*tan(Alpha1) "m/s"
V2t=V2n*tan(Alpha2) "m/s"
n_dot=700 "rpm"
omega=2*pi*n_dot/60 "rad/s"
m_dot=rho*V_dot "kg/s"
T_shaft=m_dot*(r2*V2t-r1*V1t) "Nm"
W_dot_shaft=omega*T_shaft "W"
```

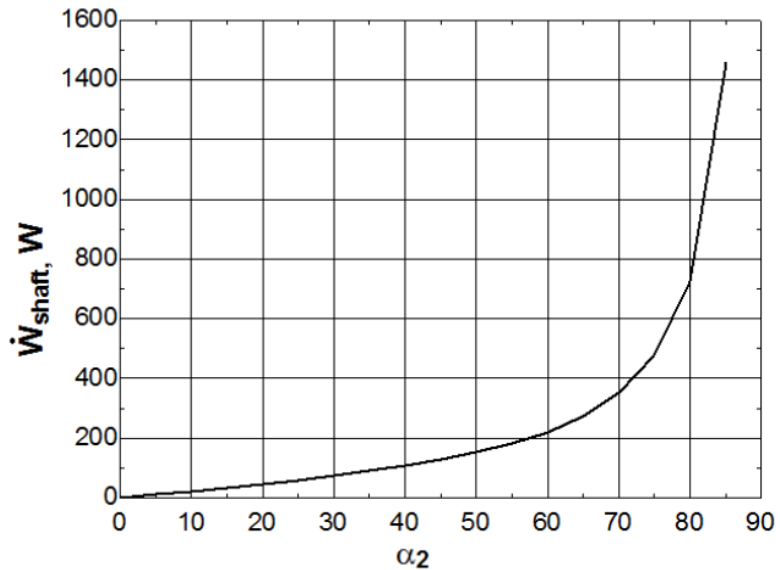

Angle, $\alpha_2^\circ$	$V_{2,t}$ , m/s	Torque, $T_{\text{shaft}}$ , Nm	Shaft power, $\dot{W}_{\text{shaft}}$ , W
0	0.00	0.00	0
5	0.39	0.15	11
10	0.78	0.31	23
15	1.18	0.47	34
20	1.61	0.63	46
25	2.06	0.81	60
30	2.55	1.01	74
35	3.10	1.22	89
40	3.71	1.46	107
45	4.42	1.74	128
50	5.27	2.07	152
55	6.31	2.49	182
60	7.66	3.02	221
65	9.48	3.73	274
70	12.15	4.78	351
75	16.50	6.50	476
80	25.07	9.87	724
85	50.53	19.90	1459

**Discussion** When  $\alpha_2 = 0$ , the shaft power is also zero as expected, since there is no turning at all. As  $\alpha_2$  approaches  $90^\circ$ , the required shaft power rises rapidly towards infinity. We can never reach  $\alpha_2 = 90^\circ$  because this would mean zero flow normal to the outlet, which is impossible.

## 6-64E

**Solution** Water enters the impeller of a centrifugal pump radially at a specified flow rate and angular speed. The torque applied to the impeller is to be determined.

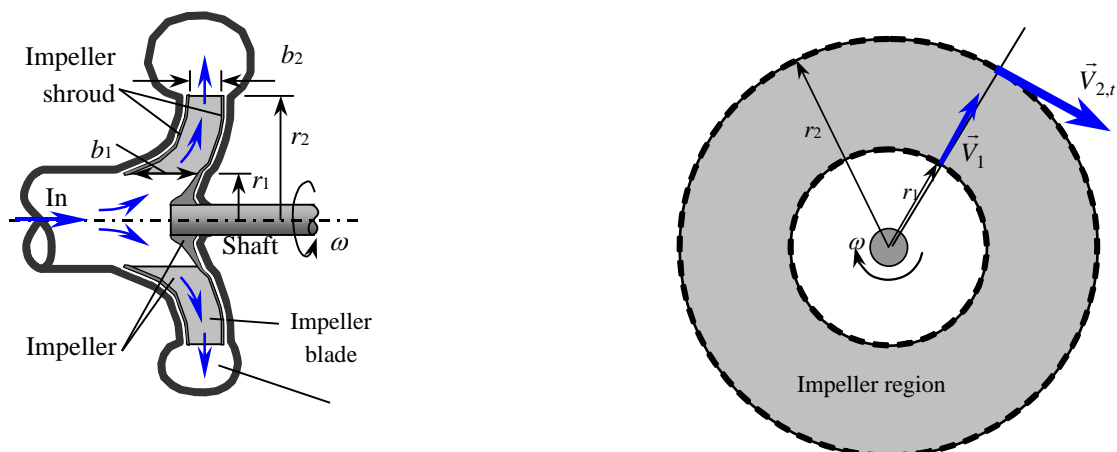

**Assumptions** 1 The flow is steady in the mean. 2 Irreversible losses are negligible.

**Properties** We take the density of water to be  $62.4 \text{ lbm/ft}^3$ .

**Analysis** Water enters the impeller normally, and thus  $V_{1,t} = 0$ . The tangential component of fluid velocity at the outlet is given to be  $V_{2,t} = 110 \text{ ft/s}$ . The inlet radius  $r_1$  is unknown, but the outlet radius is given to be  $r_2 = 1 \text{ ft}$ . The angular velocity of the propeller is

$$\omega = 2\pi i = 2\pi(500 \text{ rev/min})\left(\frac{1 \text{ min}}{60 \text{ s}}\right) = 52.36 \text{ rad/s}$$

The mass flow rate is

$$\dot{m} = \rho \dot{V} = (62.4 \text{ lbm/ft}^3)(45/60 \text{ ft}^3/\text{s}) = 46.8 \text{ lbm/s}$$

Only the tangential velocity components contribute to torque, and the application of the angular momentum equation gives

$$T_{\text{shaft}} = \dot{m}(r_2 V_{2,t} - r_1 V_{1,t}) = (46.8 \text{ lbm/s})[(1 \text{ ft})(110 \text{ ft/s}) - 0] \left(\frac{1 \text{ lbf}}{32.2 \text{ lbm} \cdot \text{ft/s}^2}\right) = 159.9 \text{ lbf} \cdot \text{ft} \cong \mathbf{160 \text{ lbf} \cdot \text{ft}}$$

**Discussion** This shaft power input corresponding to this torque is

$$\dot{W} = 2\pi i T_{\text{shaft}} = \omega T_{\text{shaft}} = (52.36 \text{ rad/s})(159.9 \text{ lbf} \cdot \text{ft}) \left(\frac{1 \text{ kW}}{737.56 \text{ lbf} \cdot \text{ft/s}}\right) = \mathbf{11.3 \text{ kW}}$$

Therefore, the minimum power input to this pump should be 11.3 kW.

## 6-65

**Solution** A three-armed sprinkler is used to water a garden. For a specified flow rate and resistance torque, the angular velocity of the sprinkler head is to be determined.

**Assumptions** 1 The flow is uniform and cyclically steady (i.e., steady from a frame of reference rotating with the sprinkler head). 2 The water is discharged to the atmosphere, and thus the gage pressure at the nozzle outlet is zero. 3 Air drag of rotating components are neglected. 4 The nozzle diameter is small compared to the moment arm, and thus we use average values of radius and velocity at the outlet.

**Properties** We take the density of water to be  $1000 \text{ kg/m}^3 = 1 \text{ kg/L}$ .

**Analysis** We take the disk that encloses the sprinkler arms as the control volume, which is a stationary control volume. The conservation of mass equation for this steady flow system is  $\dot{m}_1 = \dot{m}_2 = \dot{m}$ . Noting that the three nozzles are identical, we have  $\dot{m}_{\text{nozzle}} = \dot{m}/3$  or  $\dot{V}_{\text{nozzle}} = \dot{V}_{\text{total}}/3$  since the density of water is constant. The average jet outlet velocity relative to the nozzle and the mass flow rate are

$$V_{\text{jet}} = \frac{\dot{V}_{\text{nozzle}}}{A_{\text{jet}}} = \frac{60 \text{ L/s}}{3[\pi(0.015 \text{ m})^2/4]} \left( \frac{1 \text{ m}^3}{1000 \text{ L}} \right) = 113.2 \text{ m/s}$$

$$\dot{m}_{\text{total}} = \rho \dot{V}_{\text{total}} = (1 \text{ kg/L})(60 \text{ L/s}) = 60 \text{ kg/s}$$

The angular momentum equation can be expressed as

$$\sum M = \sum_{\text{out}} r m V - \sum_{\text{in}} r m V$$

where all moments in the counterclockwise direction are positive, and all in the clockwise direction are negative. Then the angular momentum equation about the axis of rotation becomes

$$-T_0 = -3r\dot{m}_{\text{nozzle}}V_r \quad \text{or} \quad T_0 = r\dot{m}_{\text{total}}V_r$$

Solving for the relative velocity  $V_r$  and substituting,

$$V_r = \frac{T_0}{r\dot{m}_{\text{total}}} = \frac{50 \text{ N} \cdot \text{m}}{(0.40 \text{ m})(60 \text{ kg/s})} \left( \frac{1 \text{ kg} \cdot \text{m/s}^2}{1 \text{ N}} \right) = 2.08 \text{ m/s}$$

Then the tangential and angular velocity of the nozzles become

$$V_{\text{nozzle}} = V_{\text{jet}} - V_r = 113.2 - 2.08 = 111.1 \text{ m/s}$$

$$\omega = \frac{V_{\text{nozzle}}}{r} = \frac{111.1 \text{ m/s}}{0.4 \text{ m}} = \mathbf{278 \text{ rad/s}}$$

$$\dot{n} = \frac{\omega}{2\pi} = \frac{278 \text{ rad/s}}{2\pi} \left( \frac{60 \text{ s}}{1 \text{ min}} \right) = 2652 \text{ rpm} \cong \mathbf{2650 \text{ rpm}}$$

Therefore, this sprinkler will rotate at 2650 revolutions per minute (to three significant digits).

**Discussion** The actual rotation rate will be somewhat lower than this due to air friction as the arms rotate.

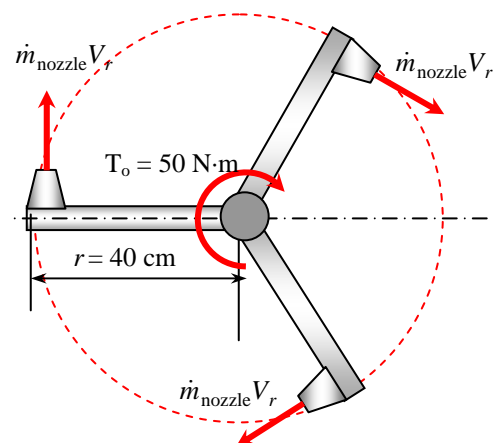
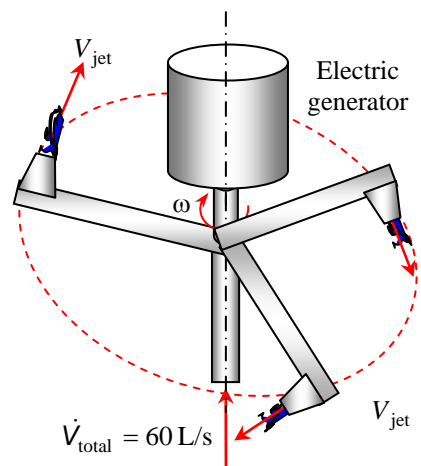

## 6-66

**Solution** A Pelton wheel is considered for power generation in a hydroelectric power plant. A relation is to be obtained for power generation, and its numerical value is to be obtained.

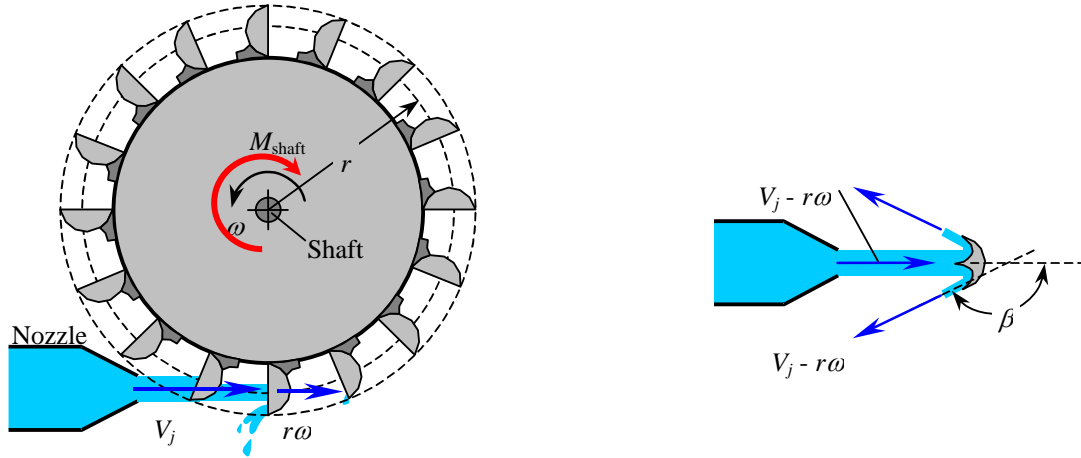

**Assumptions** 1 The flow is uniform and cyclically steady. 2 The water is discharged to the atmosphere, and thus the gage pressure at the nozzle outlet is zero. 3 Friction and losses due to air drag of rotating components are neglected. 4 The nozzle diameter is small compared to the moment arm, and thus we use average values of radius and velocity at the outlet.

**Properties** We take the density of water to be  $1000 \text{ kg/m}^3 = 1 \text{ kg/L}$ .

**Analysis** The tangential velocity of buckets corresponding to an angular velocity of  $\omega = 2\pi i$  is  $V_{\text{bucket}} = r\omega$ . Then the relative velocity of the jet (relative to the bucket) becomes

$$V_r = V_j - V_{\text{bucket}} = V_j - r\omega$$

We take the imaginary disk that contains the Pelton wheel as the control volume. The inlet velocity of the fluid into this control volume is  $V_r$ , and the component of outlet velocity normal to the moment arm is  $V_r \cos \beta$ . The angular momentum equation can be expressed as  $\sum M = \sum_{\text{out}} r\dot{m}V - \sum_{\text{in}} r\dot{m}V$  where all moments in the counterclockwise direction are positive, and all in the clockwise direction are negative. Then the angular momentum equation about the axis of rotation becomes

$$-M_{\text{shaft}} = r\dot{m}V_r \cos \beta - r\dot{m}V_r \quad \text{or} \quad M_{\text{shaft}} = r\dot{m}V_r(1 - \cos \beta) = r\dot{m}(V_j - r\omega)(1 - \cos \beta)$$

Noting that  $\dot{W}_{\text{shaft}} = 2\pi i M_{\text{shaft}} = \omega M_{\text{shaft}}$  and  $\dot{m} = \rho \dot{V}$ , the shaft power output of a Pelton turbine becomes

$$\boxed{\dot{W}_{\text{shaft}} = \rho \dot{V} r \omega (V_j - r\omega)(1 - \cos \beta)}$$

which is the desired relation. For given values, the shaft power output is determined to be

$$\dot{W}_{\text{shaft}} = (1000 \text{ kg/m}^3)(10 \text{ m}^3/\text{s})(2 \text{ m})(15.71 \text{ rad/s})(50 - 2 \times 15.71 \text{ m/s})(1 - \cos 160^\circ) \left( \frac{1 \text{ MW}}{10^6 \text{ N} \cdot \text{m/s}} \right) = \mathbf{11.3 \text{ MW}}$$

$$\text{where} \quad \omega = 2\pi i = 2\pi(150 \text{ rev/min}) \left( \frac{1 \text{ min}}{60 \text{ s}} \right) = 15.71 \text{ rad/s}$$

**Discussion** The actual power will be somewhat lower than this due to air drag and friction. Note that this is the *shaft* power; the electrical power generated by the generator connected to the shaft is lower due to generator inefficiencies.

6-67



**Solution** The previous problem is reconsidered. The effect of  $\beta$  on the power generation as  $\beta$  varies from  $0^\circ$  to  $180^\circ$  is to be determined, and the fraction of power loss at  $160^\circ$  is to be assessed.

**Analysis** The EES Equations window is printed below, followed by the tabulated and plotted results.

```
rho=1000 "kg/m3"
r=2 "m"
V_dot=10 "m3/s"
V_jet=50 "m/s"
n_dot=150 "rpm"
omega=2*pi*n_dot/60
V_r=V_jet-r*omega
m_dot=rho*V_dot
W_dot_shaft=m_dot*omega*r*V_r*(1-cos(Beta))/1E6 "MW"
W_dot_max=m_dot*omega*r*V_r^2/1E6 "MW"
Efficiency=W_dot_shaft/W_dot_max
```

Angle, $\beta^\circ$	Max power, $\dot{W}_{\max}$ , MW	Actual power, $\dot{W}_{\text{shaft}}$ , MW	Efficiency, $\eta$
0	11.7	0.00	0.000
10	11.7	0.09	0.008
20	11.7	0.35	0.030
30	11.7	0.78	0.067
40	11.7	1.37	0.117
50	11.7	2.09	0.179
60	11.7	2.92	0.250
70	11.7	3.84	0.329
80	11.7	4.82	0.413
90	11.7	5.84	0.500
100	11.7	6.85	0.587
110	11.7	7.84	0.671
120	11.7	8.76	0.750
130	11.7	9.59	0.821
140	11.7	10.31	0.883
150	11.7	10.89	0.933
160	11.7	11.32	0.970
170	11.7	11.59	0.992
180	11.7	11.68	1.000

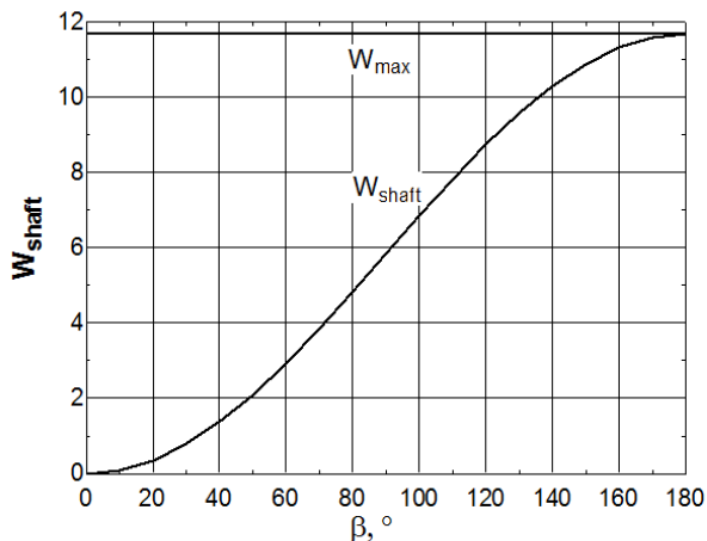

**Discussion** The efficiency of a Pelton wheel for  $\beta=160^\circ$  is 0.97. Therefore, at this angle, only 3% of the power is lost.

## Review Problems

## 6-68

**Solution** Water is deflected by an elbow. The force acting on the flanges of the elbow and the angle its line of action makes with the horizontal are to be determined.

**Assumptions** 1 The flow is steady and incompressible. 2 Frictional effects are negligible (so that the Bernoulli equation can be used). 3 The water is discharged to the atmosphere, and thus the gage pressure at the outlet is zero.

**Properties** We take the density of water to be  $1000 \text{ kg/m}^3$ .

**Analysis**

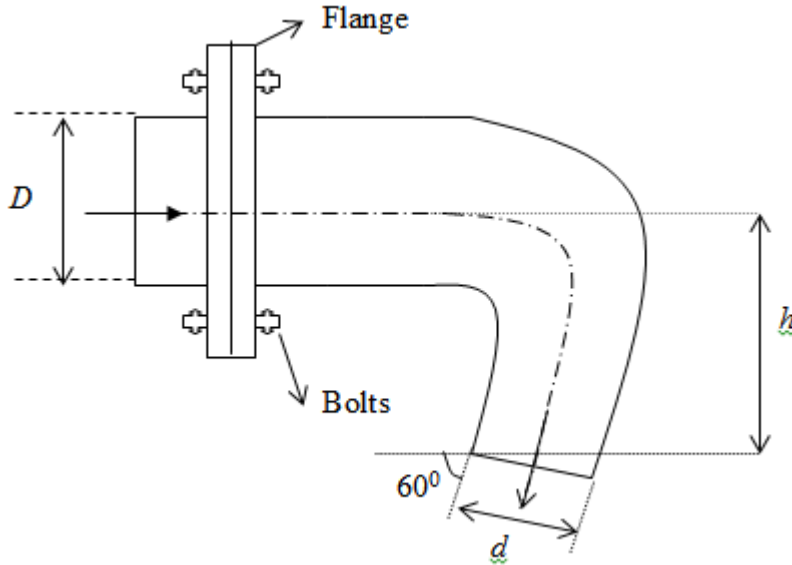

Writing Bernoulli equation between 1 (elbow entrance)-2 (exit) ;

$$P_1 + \frac{1}{2} \rho V_1^2 + \gamma z_1 = P_2 + \frac{1}{2} \rho V_2^2 + \gamma z_2 + \text{negligible losses}$$

$$V_1 = \frac{0.16}{\pi \frac{0.3^2}{4}} = 2.26 \text{ m/s} , V_2 = 20.37 \text{ m/s} , z_1 = 0.5 \text{ m} , z_2 = 0 \text{ m} , P_2 = 0$$

$$P_1 = \frac{1}{2} \rho (V_2^2 - V_1^2) - \gamma z_1 = \frac{1}{2} 1000 (20.37^2 - 2.26^2) - 9810 \times 0.5$$

$$P_1 = 20010 \text{ Pa} \cong 200 \text{ kPa}$$

Linear momentum equation for the CV gives;

$$\frac{\partial}{\partial t} \int_{cv} \vec{V} \rho dV + \int_{cs} \vec{V} \rho \vec{V} \cdot \vec{n} dA = \sum F_x$$

x component

$$V_1 \rho (-V_1) A_1 + (-V_2 \cos \theta) \rho (V_2) A_2 = P_1 A_1 + R_x$$

$$-\rho Q V_1^2 - \rho Q V_2^2 \cos \theta - P_1 A_1 = R_x$$

$$-\rho Q (V_1^2 - V_2^2 \cos \theta) - P_1 A_1 = R_x$$

$$-1000 \times 0.16 (2.26^2 + 20.37^2 \cos 60) - 200010 \pi \frac{0.3^2}{4} = R_x$$

$$R_x = -48150 \text{ N (left)}$$

y component

$$0 + (-V_2 \sin \theta) \rho V_2 A_2 = -W_{\text{water,cv}} + R_y$$

$$-\rho Q V_2^2 \sin \theta + W_{\text{cv}} = R_y$$

$$-1000 \times 20.37^2 \sin 60 + 9810 \times 0.03 = R_y$$

$$R_y = -359052 \text{ N (down)}$$

These forces are exerted by elbow on water confined by CV. The force exerted by water on elbow is therefore;

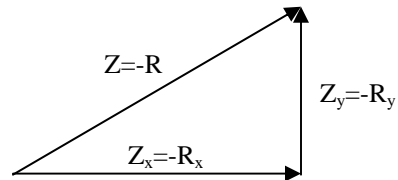

$$Z = -R = \sqrt{48150^2 + 359052^2} = 362266 \text{ N} \cong \mathbf{362 \text{ kN}}$$

and

$$\tan \beta = \frac{R_y}{R_x} = \frac{359,052 \text{ N}}{48,150 \text{ N}} = 7.457 \rightarrow \beta = \mathbf{82.4^\circ}$$

## 6-69

**Solution** Water is deflected by an elbow. The force acting on the flanges of the elbow and the angle its line of action makes with the horizontal are to be determined by taking into consideration of the weight of the elbow.

**Assumptions** 1 The flow is steady and incompressible. 2 Frictional effects are negligible (so that the Bernoulli equation can be used). 3 The water is discharged to the atmosphere, and thus the gage pressure at the outlet is zero.

**Properties** We take the density of water to be  $1000 \text{ kg/m}^3$ .

**Analysis**

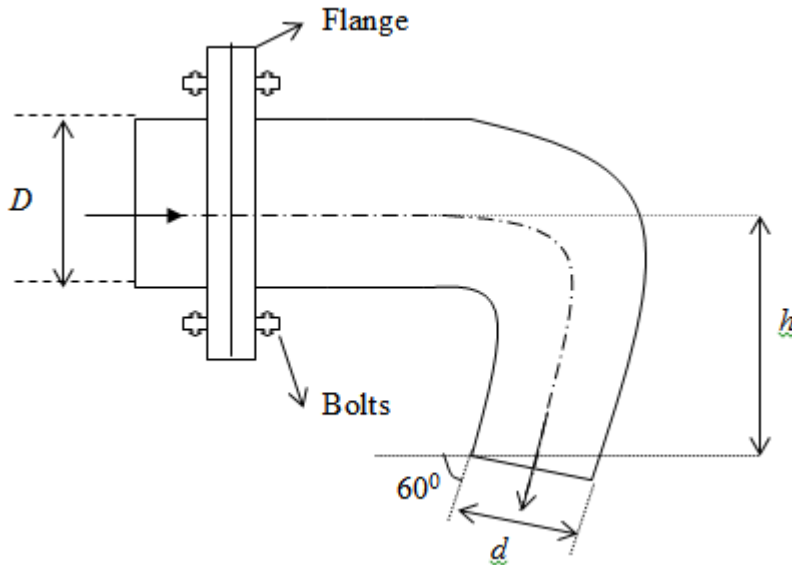

Writing Bernoulli equation between 1 (elbow entrance)-2 (exit) ;

$$P_1 + \frac{1}{2} \rho V_1^2 + \gamma z_1 = P_2 + \frac{1}{2} \rho V_2^2 + \gamma z_2 + \text{negligible losses}$$

$$V_1 = \frac{0.16}{\pi \frac{0.3^2}{4}} = 2.26 \text{ m/s} , V_2 = 20.37 \text{ m/s} , z_1 = 0.5 \text{ m} , z_2 = 0 \text{ m} , P_2 = 0$$

$$P_1 = \frac{1}{2} \rho (V_2^2 - V_1^2) - \gamma z_1 = \frac{1}{2} 1000 (20.37^2 - 2.26^2) - 9810 \times 0.5$$

$$P_1 = 20010 \text{ Pa} \cong 200 \text{ kPa}$$

Linear momentum equation for the CV gives;

$$\frac{\partial}{\partial t} \int_{cv} \vec{V} \rho dV + \int_{cs} \vec{V} \rho \vec{V} \cdot \vec{n} dA = \sum F_x$$

x component

$$V_1 \rho (-V_1) A_1 + (-V_2 \cos \theta) \rho (V_2) A_2 = P_1 A_1 + R_x$$

$$-\rho Q V_1^2 - \rho Q V_2^2 \cos \theta - P_1 A_1 = R_x$$

$$-\rho Q (V_1^2 - V_2^2 \cos \theta) - P_1 A_1 = R_x$$

$$-1000 \times 0.16 (2.26^2 + 20.37^2 \cos 60) - 20010 \pi \frac{0.3^2}{4} = R_x$$

$$R_x = -48150 \text{ N (left)}$$



To include elbow weight we must modify y-momentum equation as follows:

y component:

$$0 + (-V_2 \sin \theta) \rho V_2 A_2 = -W_{water,cv} - W_{elbow} + R_y$$

$$-\rho Q V_2^2 \sin \theta + W_{water,cv} + W_{elbow} = R_y$$

$$-1000 \times 20.37^2 \sin 60 + 9810 \times 0.03 + 5 \times 9.81 = R_y$$

$$R_y \approx -359003 \text{ N (down)}$$

These forces are exerted by elbow on water confined by CV. The force exerted by water on elbow is therefore;

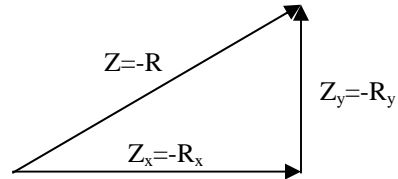

$$Z = -R = \sqrt{48150^2 + 359052^2} = 362266 \text{ N} \cong \mathbf{362 \text{ kN}}$$

and

$$\tan \beta = \frac{R_y}{R_x} = \frac{359,003 \text{ N}}{48,150 \text{ N}} = 7.457 \rightarrow \beta = \mathbf{82.4^\circ}$$

Therefore we could neglect the weight of the elbow.

6-70

**Solution** A horizontal water jet is deflected by a cone. The external force needed to maintain the motion of the cone is to be determined.

**Assumptions** 1 The flow is steady and incompressible. 2 The flow is uniform in each section.

**Properties** We take the density of water to be 1000 kg/m<sup>3</sup>.

**Analysis**

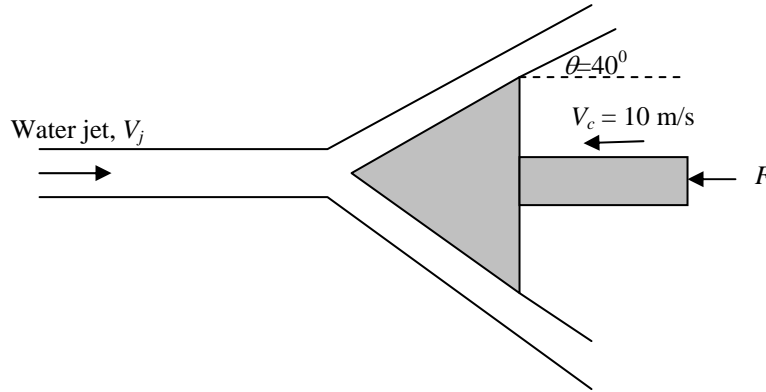

We chose a CV moving with  $V_c$  to left.  $W_1$  and  $W_2$  are the relative velocities with respect to the CV. Conservation of mass gives

$$0 = \frac{\partial}{\partial t} \int_{cv} \rho dV + \int_{cs} \rho \left( \vec{W} - \vec{V}_{cv} \right) \cdot \vec{n} dA \dots\dots\dots 1$$

Conservation of momentum gives

$$F = \frac{\partial}{\partial t} \int_{cv} W \rho dV + \int_{cs} \vec{W} \rho \vec{W} \cdot \vec{n} dA \dots\dots\dots 2$$

From Eq. 1

$$-W_1 A_1 + W_2 A_2 = 0$$

$$W_2 A_2 = W_1 A_1 = (V_j + V_c) A_j, \text{ therefore } A_1 = A_2 = A_j$$

From eq.2

$$F_x = - \int_{A_1} W_1 \rho (-W_1) dA_1 + \int_{A_2} (W_2 \cos \theta) \rho (+W_2) dA_2$$

$$W_1 = W_2 = V_j + V_c = 25 + 10 = 35 \text{ m/s}$$

Then,  $F_x = -\rho W_1 A_j + \rho W_2^2 A_j \cos \theta$

$$= (\cos \theta - 1) \rho W_2^2 A_j$$

$$= (\cos 40 - 1) \times 1000 \times 35^2 \frac{\pi}{4} 0.12^2$$

$$F_x = -3241 \text{ N}$$

Therefore,

$$F_x = \mathbf{3241 \text{ N to left}}$$

## 6-71

**Solution** Water enters a two-armed sprinkler vertically, and leaves the nozzles horizontally at an angle to tangential direction. For a specified flow rate and discharge angle, the rate of rotation of the sprinkler and the torque required to prevent the sprinkler from rotating are to be determined. **✓EES**

**Assumptions** 1 The flow is uniform and cyclically steady (i.e., steady from a frame of reference rotating with the sprinkler head). 2 The water is discharged to the atmosphere, and thus the gage pressure at the nozzle outlet is zero. 3 Frictional effects and air drag of rotating components are neglected. 4 The nozzle diameter is small compared to the moment arm, and thus we use average values of radius and velocity at the outlet.

**Properties** We take the density of water to be  $1000 \text{ kg/m}^3 = 1 \text{ kg/L}$ .

**Analysis** We take the disk that encloses the sprinkler arms as the control volume, which is a stationary control volume. The conservation of mass equation for this symmetrical steady flow system is  $\dot{m}_1 = \dot{m}_2 = \dot{m}$ . Noting that the two nozzles are identical, we have  $\dot{m}_{\text{jet}} = \dot{m}_{\text{total}} / 2$  or  $\dot{V}_{\text{jet}} = \dot{V}_{\text{total}} / 2$  since the density of water is constant. The average jet outlet velocity relative to the nozzle is

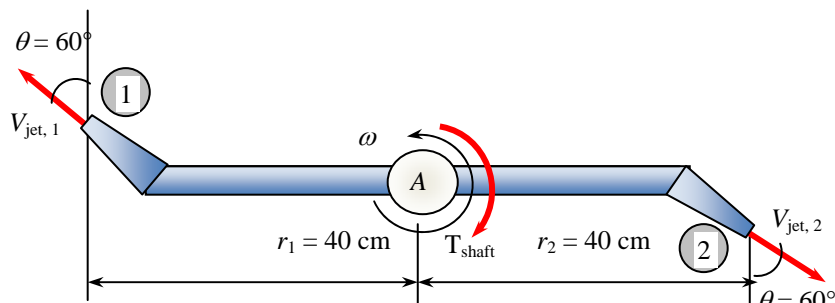

$$V_{\text{jet},r} = \frac{\dot{V}_{\text{jet}}}{A_{\text{jet}}} = \frac{10/2 \text{ L/s}}{\pi(0.012 \text{ m})^2/4} \left( \frac{1 \text{ m}^3}{1000 \text{ L}} \right) = 44.21 \text{ m/s}$$

The angular momentum equation about the axis of rotation can be expressed as  $\sum M = \sum_{\text{out}} r\dot{m}V - \sum_{\text{in}} r\dot{m}V$  where  $r$  is the

average moment arm,  $V$  is the average absolute speed (relative to an inertial reference frame), all moments in the counterclockwise direction are positive, and all moments in the clockwise direction are negative. Momentum flows in the clockwise direction (as in this case) are also negative. The absolute water jet speed in the tangential direction is the difference between the tangential component of the water jet speed and the nozzle speed  $V_{\text{nozzle}} = \omega r = 2\pi\dot{m}r$ . Thus,  $V_{\text{jet},t} = V_{\text{jet},r} \cos \theta - V_{\text{nozzle}} = V_{\text{jet},r} \cos \theta - \omega r$ . Then the angular momentum equation becomes

$$-T_{\text{shaft}} = -r_1 \dot{m}_{\text{jet},1} V_{\text{jet},t,1} - r_2 \dot{m}_{\text{jet},2} V_{\text{jet},t,2} \quad \rightarrow \quad T_{\text{shaft}} = r_1 \dot{m}_{\text{jet},1} (V_{\text{jet},r,1} \cos \theta_1 - \omega r_1) + r_2 \dot{m}_{\text{jet},2} (V_{\text{jet},r,2} \cos \theta_2 - \omega r_2)$$

Noting that  $r_1 = r_2 = r$ ,  $\theta_1 = \theta_2 = \theta$ ,  $V_{\text{jet},r,1} = V_{\text{jet},r,2} = V_{\text{jet},r}$ , and, the angular momentum equation becomes

$$T_{\text{shaft}} = r \rho \dot{V}_{\text{total}} (V_{\text{jet},r} \cos \theta - \omega r)$$

(a) In the case of free spin with no frictional effects, we have  $T_{\text{shaft}} = 0$  and thus  $V_{\text{jet},r} \cos \theta - \omega r = 0$ . Then angular speed and the rate of rotation of sprinkler head becomes

$$\omega = \frac{V_{\text{jet},r} \cos \theta}{r} = \frac{(44.21 \text{ m/s}) \cos 60^\circ}{0.40 \text{ m}} = 55.26 \text{ rad/s} \quad \text{and} \quad \dot{n} = \frac{\omega}{2\pi} = \frac{55.26 \text{ rad/s}}{2\pi} \left( \frac{60 \text{ s}}{1 \text{ min}} \right) = \mathbf{528 \text{ rpm}}$$

(b) When the sprinkler is prevented from rotating, we have  $\omega = 0$ . Then the required torque becomes

$$T_{\text{shaft}} = r \rho \dot{V}_{\text{total}} V_{\text{jet},r} \cos \theta = (0.4 \text{ m})(1 \text{ kg/L})(10 \text{ L/s})(44.21 \text{ m/s}) \cos 60^\circ \left( \frac{1 \text{ N}}{1 \text{ kg} \cdot \text{m/s}^2} \right) = \mathbf{88.4 \text{ N} \cdot \text{m}}$$

**Discussion** The rate of rotation determined in (a) will be lower in reality because of frictional effects and air drag.

## 6-72

**Solution** Water enters a two-armed sprinkler vertically, and leaves the nozzles horizontally at an angle to tangential direction. For a specified flow rate and discharge angle, the rate of rotation of the sprinkler and the torque required to prevent the sprinkler from rotating are to be determined.

**Assumptions** 1 The flow is uniform and cyclically steady (i.e., steady from a frame of reference rotating with the sprinkler head). 2 The water is discharged to the atmosphere, and thus the gage pressure at the nozzle outlet is zero. 3 Frictional effects and air drag of rotating components are neglected. 4 The nozzle diameter is small compared to the moment arm, and thus we use average values of radius and velocity at the outlet.

**Properties** We take the density of water to be  $1000 \text{ kg/m}^3 = 1 \text{ kg/L}$ .

**Analysis** We take the disk that encloses the sprinkler arms as the control volume, which is a stationary control volume. The conservation of mass equation for this symmetrical steady flow system is  $\dot{m}_1 = \dot{m}_2 = \dot{m}$ . Noting that the two nozzles are identical, we have  $\dot{m}_{\text{jet}} = \dot{m}_{\text{total}} / 2$  or  $\dot{V}_{\text{jet}} = \dot{V}_{\text{total}} / 2$  since the density of water is constant. The average jet outlet velocity relative to the nozzle is

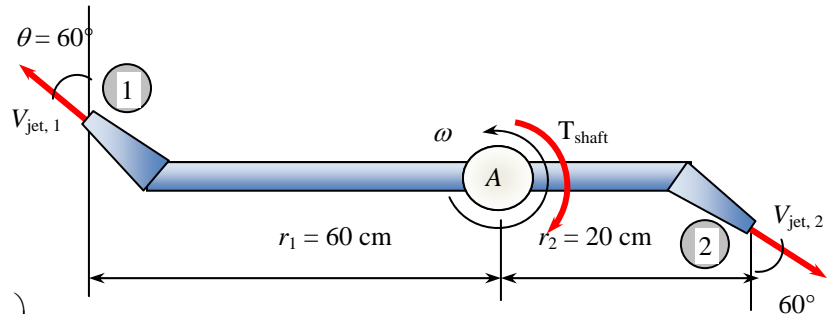

$$V_{\text{jet},r} = \frac{\dot{V}_{\text{jet}}}{A_{\text{jet}}} = \frac{10/2 \text{ L/s}}{\pi(0.012 \text{ m})^2/4} \left( \frac{1 \text{ m}^3}{1000 \text{ L}} \right) = 44.21 \text{ m/s}$$

The angular momentum equation about the axis of rotation can be expressed as  $\sum M = \sum_{\text{out}} r\dot{m}V - \sum_{\text{in}} r\dot{m}V$  where  $r$  is the average moment arm,  $V$  is the average absolute speed (relative to an inertial reference frame), all moments in the counterclockwise direction are positive, and all moments in the clockwise direction are negative. Momentum flows in the clockwise direction (as in this case) are also negative. The absolute water jet speed in the tangential direction is the difference between the tangential component of the water jet speed and the nozzle speed  $V_{\text{nozzle}} = \omega r = 2\pi n r$ . Thus,  $V_{\text{jet},t} = V_{\text{jet},r,t} - V_{\text{nozzle}} = V_{\text{jet},r} \cos \theta - \omega r$ . Then the angular momentum equation becomes

$$-T_{\text{shaft}} = -r_1 \dot{m}_{\text{jet},1} V_{\text{jet},t,1} - r_2 \dot{m}_{\text{jet},2} V_{\text{jet},t,2} \quad \rightarrow \quad T_{\text{shaft}} = r_1 \dot{m}_{\text{jet},1} (V_{\text{jet},r,1} \cos \theta_1 - \omega r_1) + r_2 \dot{m}_{\text{jet},2} (V_{\text{jet},r,2} \cos \theta_2 - \omega r_2)$$

Noting that  $\theta_1 = \theta_2 = \theta$ ,  $V_{\text{jet},r,1} = V_{\text{jet},r,2} = V_{\text{jet},r}$ , and, the angular momentum equation becomes

$$T_{\text{shaft}} = \rho \dot{V}_{\text{jet}} [r_1 (V_{\text{jet},r} \cos \theta - \omega r_1) + r_2 (V_{\text{jet},r} \cos \theta - \omega r_2)] \quad \text{or} \quad T_{\text{shaft}} = \rho \dot{V}_{\text{jet}} [(r_1 + r_2) V_{\text{jet},r} \cos \theta - (r_1^2 + r_2^2) \omega]$$

(a) In the case of free spin with no frictional effects, we have  $T_{\text{shaft}} = 0$  and thus  $0 = (r_1 + r_2) V_{\text{jet},r} \cos \theta - (r_1^2 + r_2^2) \omega$ .

Then angular speed and the rate of rotation of sprinkler head becomes

$$\omega = \frac{(r_1 + r_2) V_{\text{jet},r} \cos \theta}{r_1^2 + r_2^2} = \frac{(0.6 + 0.2 \text{ m})(44.21 \text{ m/s}) \cos 60^\circ}{(0.60 \text{ m})^2 + (0.20 \text{ m})^2} = 44.21 \text{ rad/s}$$

and

$$\dot{n} = \frac{\omega}{2\pi} = \frac{44.21 \text{ rad/s}}{2\pi} \left( \frac{60 \text{ s}}{1 \text{ min}} \right) = 422.2 \text{ rpm} \cong \mathbf{422 \text{ rpm}}$$

(b) When the sprinkler is prevented from rotating, we have  $\omega = 0$ . Then the required torque becomes

$$T_{\text{shaft}} = (r_1 + r_2) \rho \dot{V}_{\text{jet}} V_{\text{jet},r} \cos \theta = (0.6 + 0.2 \text{ m})(1 \text{ kg/L})(10/2 \text{ L/s})(44.21 \text{ m/s}) \cos 60^\circ \left( \frac{1 \text{ N}}{1 \text{ kg} \cdot \text{m/s}^2} \right) = \mathbf{88.4 \text{ N} \cdot \text{m}}$$

**Discussion** The rate of rotation determined in (a) will be lower in reality because of frictional effects and air drag.

## 6-73

**Solution** A horizontal water jet strikes a vertical stationary flat plate normally at a specified velocity. For a given flow velocity, the anchoring force needed to hold the plate in place is to be determined.

**Assumptions** **1** The flow is steady and incompressible. **2** The water splatters off the sides of the plate in a plane normal to the jet. **3** The water jet is exposed to the atmosphere, and thus the pressure of the water jet and the splattered water is the atmospheric pressure which is disregarded since it acts on the entire control surface. **4** The vertical forces and momentum fluxes are not considered since they have no effect on the horizontal reaction force. **5** Jet flow is nearly uniform and thus the momentum-flux correction factor can be taken to be unity,  $\beta \cong 1$ .

**Properties** We take the density of water to be  $1000 \text{ kg/m}^3$ .

**Analysis** We take the plate as the control volume such that it contains the entire plate and cuts through the water jet and the support bar normally, and the direction of flow as the positive direction of  $x$  axis. We take the reaction force to be in the negative  $x$  direction. The momentum equation for steady flow in the  $x$  (flow) direction reduces in this case to

$$\sum \vec{F} = \sum_{\text{out}} \beta \dot{m} \vec{V} - \sum_{\text{in}} \beta \dot{m} \vec{V} \quad \rightarrow \quad -F_{Rx} = -\beta_i \dot{m}_i V_i \quad \rightarrow \quad F_{Rx} = \beta_i \dot{m} V$$

We note that the reaction force acts in the opposite direction to flow, and we should not forget the negative sign for forces and velocities in the negative  $x$ -direction. The mass flow rate of water is

$$\dot{m} = \rho \dot{V} = \rho AV = \rho \frac{\pi D^2}{4} V = (1000 \text{ kg/m}^3) \frac{\pi (0.06 \text{ m})^2}{4} (25 \text{ m/s}) = 70.6858 \text{ kg/s}$$

Substituting, the reaction force is determined to be

$$F_{Rx} = (1)(70.6858 \text{ kg/s})(25 \text{ m/s}) = 1767 \text{ N} \cong \mathbf{1770 \text{ N}}$$

Therefore, a force of approximately 1770 N must be applied to the plate in the opposite direction to the flow to hold it in place.

**Discussion** In reality, some water may be scattered back, and this would add to the reaction force of water. If we do not approximate the water jet as uniform, the momentum flux correction factor  $\beta$  would factor in. For example, if  $\beta = 1.03$  (approximate value for fully developed pipe flow), the force would *increase* by 3%. This is because the actual nonuniform jet has *more* momentum than the uniform jet.

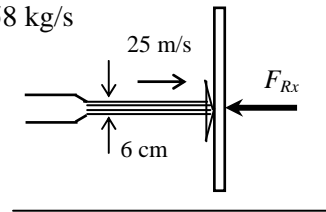

## 6-74

**Solution** Steady developing laminar flow is considered in a constant horizontal diameter discharge pipe. A relation is to be obtained for the horizontal force acting on the bolts that hold the pipe.

**Assumptions** **1** The flow is steady, laminar, and incompressible. **2** The flow is fully developed at the end of the pipe section considered. **3** The velocity profile at the pipe inlet is uniform and thus the momentum-flux correction factor is  $\beta_1 = 1$ . **4** The momentum-flux correction factor is  $\beta = 2$  at the outlet.

**Analysis** We take the developing flow section of the pipe (including the water inside) as the control volume. We assume the reaction force to act in the positive direction. Noting that the flow is incompressible and thus the average velocity is constant  $V_1 = V_2 = V$ , the momentum equation for steady flow in the  $z$  (flow) direction in this case reduces to

$$\begin{aligned}\sum \vec{F} &= \sum_{\text{out}} \beta \dot{m} \vec{V} - \sum_{\text{in}} \beta \dot{m} \vec{V} \\ -F_R + P_1 A_c - P_2 A_c &= \dot{m} \beta_2 V - \dot{m} \beta_1 V \\ F_R &= (P_1 - P_2) A_c + \dot{m} V (\beta_1 - \beta_2) \\ &= (P_1 - P_2) A_c + \dot{m} V (1 - 2) \\ &= (P_1 - P_2) \pi D^2 / 4 - \dot{m} V\end{aligned}$$

Or, using the definition of the mass flow rate,

$$F_R = (P_1 - P_2) \pi D^2 / 4 - [\rho \pi D^2 / 4] V^2$$

Or,

$$F_R = \frac{\pi D^2}{4} [(P_1 - P_2) - \rho V^2]$$

**Discussion** Note that the cause of this reaction force is non-uniform velocity profile at the end.

---

## 6-75

**Solution** A fireman was hit by a nozzle held by a tripod with a rated holding force. The accident is to be investigated by calculating the water velocity, the flow rate, and the nozzle velocity.

**Assumptions** **1** The flow is steady and incompressible. **2** The water jet is exposed to the atmosphere, and thus the pressure of the water jet is the atmospheric pressure, which is disregarded since it acts on all surfaces. **3** Gravitational effects and vertical forces are disregarded since the horizontal resistance force is to be determined. **4** Jet flow is nearly uniform and thus the momentum-flux correction factor can be taken to be unity,  $\beta \cong 1$ . **5** Upstream pressure and momentum effects are ignored.

**Properties** We take the density of water to be  $1000 \text{ kg/m}^3$ .

**Analysis** We take the nozzle and the horizontal portion of the hose as the system such that water enters the control volume vertically and outlets horizontally (this way the pressure force and the momentum flux at the inlet are in the vertical direction, with no contribution to the force balance in the horizontal direction, and designate the entrance by 1 and the outlet by 2. We also designate the horizontal coordinate by  $x$  (with the direction of flow as being the positive direction).

The momentum equation for steady flow is  $\sum \vec{F} = \sum_{\text{out}} \beta \dot{m} \vec{V} - \sum_{\text{in}} \beta \dot{m} \vec{V}$ . We let the horizontal force applied by the tripod to the nozzle to hold it be  $F_{Rx}$ , and assume it to be in the positive  $x$  direction. Then the momentum equation along the  $x$  direction becomes

$$F_{Rx} = \dot{m}V_e - 0 = \dot{m}V = \rho AVV = \rho \frac{\pi D^2}{4} V^2 \rightarrow (1800 \text{ N}) \left( \frac{1 \text{ kg} \cdot \text{m/s}^2}{1 \text{ N}} \right) = (1000 \text{ kg/m}^3) \frac{\pi (0.05 \text{ m})^2}{4} V^2$$

Solving for the water outlet velocity gives  $V = 30.3 \text{ m/s}$ . Then the water flow rate becomes

$$\dot{V} = AV = \frac{\pi D^2}{4} V = \frac{\pi (0.05 \text{ m})^2}{4} (30.3 \text{ m/s}) = 0.0595 \text{ m}^3/\text{s}$$

When the nozzle was released, its acceleration must have been

$$a_{\text{nozzle}} = \frac{F}{m_{\text{nozzle}}} = \frac{1800 \text{ N}}{10 \text{ kg}} \left( \frac{1 \text{ kg} \cdot \text{m/s}^2}{1 \text{ N}} \right) = 180 \text{ m/s}^2$$

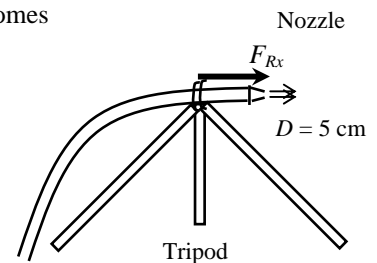

Assuming the reaction force acting on the nozzle and thus its acceleration to remain constant, the time it takes for the nozzle to travel 60 cm and the nozzle velocity at that moment were (note that both the distance  $x$  and the velocity  $V$  are zero at time  $t = 0$ )

$$x = \frac{1}{2} at^2 \rightarrow t = \sqrt{\frac{2x}{a}} = \sqrt{\frac{2(0.6 \text{ m})}{180 \text{ m/s}^2}} = 0.0816 \text{ s}$$

$$V = at = (180 \text{ m/s}^2)(0.0816 \text{ s}) = 14.7 \text{ m/s}$$

Thus we conclude that the nozzle hit the fireman with a velocity of 14.7 m/s.

**Discussion** Engineering analyses such as this one are frequently used in accident reconstruction cases, and they often form the basis for judgment in courts.

## 6-76

**Solution** During landing of an airplane, the thrust reverser is lowered in the path of the exhaust jet, which deflects the exhaust and provides braking. The thrust of the engine and the braking force produced after the thrust reverser is deployed are to be determined.

**Assumptions** **1** The flow of exhaust gases is steady and one-dimensional. **2** The exhaust gas stream is exposed to the atmosphere, and thus its pressure is the atmospheric pressure. **3** The velocity of exhaust gases remains constant during reversing. **4** Jet flow is nearly uniform and thus the momentum-flux correction factor can be taken to be unity,  $\beta \cong 1$ .

**Analysis** (a) The thrust exerted on an airplane is simply the momentum flux of the combustion gases in the reverse direction,

$$\text{Thrust} = \dot{m}_{ex} V_{ex} = (18 \text{ kg/s})(300 \text{ m/s}) \left( \frac{1 \text{ N}}{1 \text{ kg} \cdot \text{m/s}^2} \right) = \mathbf{5400 \text{ N}}$$

(b) We take the thrust reverser as the control volume such that it cuts through both exhaust streams normally and the connecting bars to the airplane, and the direction of airplane as the positive direction of  $x$  axis. The momentum equation for steady flow in the  $x$  direction reduces to

$$\sum \vec{F} = \sum_{\text{out}} \beta \dot{m} \vec{V} - \sum_{\text{in}} \beta \dot{m} \vec{V} \quad \rightarrow \quad F_{Rx} = \dot{m}(V) \cos 20^\circ - \dot{m}(-V) \quad \rightarrow \quad F_{Rx} = (1 + \cos 20^\circ) \dot{m} V_i$$

Substituting, the reaction force is determined to be

$$F_{Rx} = (1 + \cos 30^\circ)(18 \text{ kg/s})(300 \text{ m/s}) = 10,077 \text{ N}$$

The braking force acting on the plane is equal and opposite to this force,

$$F_{\text{braking}} = 10,077 \text{ N} \cong \mathbf{10,100 \text{ N}}$$

Therefore, a braking force of 10,100 N develops in the opposite direction to flight.

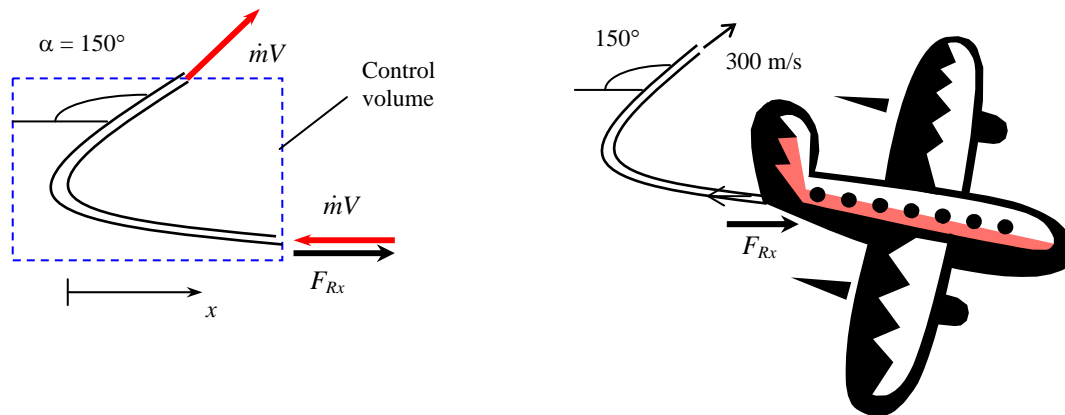

**Discussion** This problem can be solved more generally by measuring the reversing angle from the direction of exhaust gases ( $\alpha = 0$  when there is no reversing). When  $\alpha < 90^\circ$ , the reversed gases are discharged in the negative  $x$  direction, and the momentum equation reduces to

$$F_{Rx} = \dot{m}(-V) \cos \alpha - \dot{m}(-V) \quad \rightarrow \quad F_{Rx} = (1 - \cos \alpha) \dot{m} V_i$$

This equation is also valid for  $\alpha > 90^\circ$  since  $\cos(180^\circ - \alpha) = -\cos \alpha$ . Using  $\alpha = 150^\circ$ , for example, gives

$$F_{Rx} = (1 - \cos 150^\circ) \dot{m} V_i = (1 + \cos 30^\circ) \dot{m} V_i, \text{ which is identical to the solution above.}$$





6-77

**Solution** The previous problem is reconsidered. The effect of thrust reverser angle on the braking force exerted on the airplane as the reverser angle varies from 0 (no reversing) to 180° (full reversing) in increments of 10° is to be investigated.

**Analysis** The EES *Equations* window is printed below, followed by the tabulated and plotted results.

$$V_{\text{jet}}=250 \text{ "m/s"}$$

$$m_{\text{dot}}=18 \text{ "kg/s"}$$

$$F_{\text{Rx}}=(1-\cos(\alpha))*m_{\text{dot}}*V_{\text{jet}} \text{ "N"}$$

Reversing angle, $\alpha^\circ$	Braking force $F_{\text{brake}}$ , N
0	0
10	68
20	271
30	603
40	1053
50	1607
60	2250
70	2961
80	3719
90	4500
100	5281
110	6039
120	6750
130	7393
140	7947
150	8397
160	8729
170	8932
180	9000

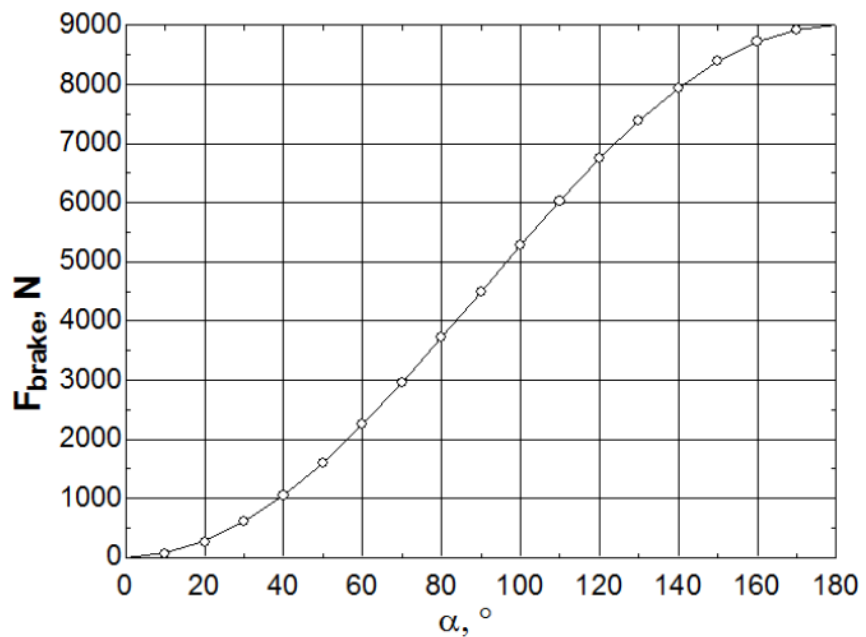

**Discussion** As expected, the braking force is zero when the angle is zero (no deflection), and maximum when the angle is 180° (completely reversed). Of course, it is impossible to completely reverse the flow, since the jet exhaust cannot be directed back into the engine.

## 6-78E

**Solution** The rocket of a spacecraft is fired in the opposite direction to motion. The deceleration, the velocity change, and the thrust are to be determined.

**Assumptions** **1** The flow of combustion gases is steady and one-dimensional during the firing period, but the flight of the spacecraft is unsteady. **2** There are no external forces acting on the spacecraft, and the effect of pressure force at the nozzle outlet is negligible. **3** The mass of discharged fuel is negligible relative to the mass of the spacecraft, and thus the spacecraft may be treated as a solid body with a constant mass. **4** The nozzle is well-designed such that the effect of the momentum-flux correction factor is negligible, and thus  $\beta \cong 1$ .

**Analysis** (a) We choose a reference frame in which the control volume moves with the spacecraft. Then the velocities of fluid streams become simply their relative velocities (relative to the moving body). We take the direction of motion of the spacecraft as the positive direction along the  $x$  axis. There are no external forces acting on the spacecraft, and its mass is nearly constant. Therefore, the spacecraft can be treated as a solid body with constant mass, and the momentum equation in this case is

$$0 = \frac{d(m\vec{V})_{CV}}{dt} + \sum_{out} \beta \dot{m} \vec{V} - \sum_{in} \beta \dot{m} \vec{V} \rightarrow m_{space} \frac{d\vec{V}_{space}}{dt} = -\dot{m}_f \vec{V}_f$$

Noting that the motion is on a straight line and the discharged gases move in the positive  $x$  direction (to slow down the spacecraft), we write the momentum equation using magnitudes as

$$m_{space} \frac{dV_{space}}{dt} = -\dot{m}_f V_f \rightarrow \frac{dV_{space}}{dt} = -\frac{\dot{m}_f}{m_{space}} V_f$$

Substituting, the deceleration of the spacecraft during the first 5 seconds is determined to be

$$a_{space} = \frac{dV_{space}}{dt} = -\frac{\dot{m}_f}{m_{space}} V_f = -\frac{150 \text{ lbm/s}}{25,000 \text{ lbm}} (5000 \text{ ft/s}) = -30.0 \text{ ft/s}^2$$

(b) Knowing the deceleration, which is constant, the velocity change of the spacecraft during the first 5 seconds is determined from the definition of acceleration  $a_{space} = dV_{space} / dt$  to be

$$dV_{space} = a_{space} dt \rightarrow \Delta V_{space} = a_{space} \Delta t = (-30.0 \text{ ft/s}^2)(5 \text{ s}) = -150 \text{ ft/s}$$

(c) The thrust exerted on the system is simply the momentum flux of the combustion gases in the reverse direction,

$$\text{Thrust} = F_R = -\dot{m}_f V_f = -(150 \text{ lbm/s})(5000 \text{ ft/s}) \left( \frac{1 \text{ lbf}}{32.2 \text{ lbm} \cdot \text{ft/s}^2} \right) = -23,290 \text{ lbf} \cong -23,300 \text{ lbf}$$

Therefore, if this spacecraft were attached somewhere, it would exert a force of 23,300 lbf (equivalent to the weight of 23,300 lbm of mass on earth) to its support in the negative  $x$  direction.

**Discussion** In Part (b) we approximate the deceleration as constant. However, since mass is lost from the spacecraft during the time in which the jet is on, a more accurate solution would involve solving a differential equation. Here, the time span is short, and the lost mass is likely negligible compared to the total mass of the spacecraft, so the more complicated analysis is not necessary.

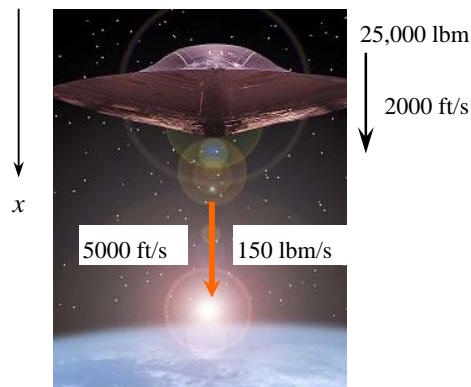

## 6-79

**Solution** An ice skater is holding a flexible hose (essentially weightless) which directs a stream of water horizontally at a specified velocity. The velocity and the distance traveled in 5 seconds, and the time it takes to move 5 m and the velocity at that moment are to be determined.

**Assumptions** **1** Friction between the skates and ice is negligible. **2** The flow of water is steady and one-dimensional (but the motion of skater is unsteady). **3** The ice skating arena is level, and the water jet is discharged horizontally. **4** The mass of the hose and the water in it is negligible. **5** The skater is standing still initially at  $t = 0$ . **6** Jet flow is nearly uniform and thus the momentum-flux correction factor can be taken to be unity,  $\beta \cong 1$ .

**Properties** We take the density of water to be  $1000 \text{ kg/m}^3$ .

**Analysis** (a) The mass flow rate of water through the hose is

$$\dot{m} = \rho AV = \rho \frac{\pi D^2}{4} V = (1000 \text{ kg/m}^3) \frac{\pi (0.02 \text{ m})^2}{4} (10 \text{ m/s}) = 3.14 \text{ kg/s}$$

The thrust exerted on the skater by the water stream is simply the momentum flux of the water stream, and it acts in the reverse direction,

$$F = \text{Thrust} = \dot{m}V = (3.14 \text{ kg/s})(10 \text{ m/s}) \left( \frac{1 \text{ N}}{1 \text{ kg} \cdot \text{m/s}^2} \right) = 31.4 \text{ N (constant)}$$

The acceleration of the skater is determined from Newton's 2<sup>nd</sup> law of motion  $F = ma$  where  $m$  is the mass of the skater,

$$a = \frac{F}{m} = \frac{31.4 \text{ N}}{60 \text{ kg}} \left( \frac{1 \text{ kg} \cdot \text{m/s}^2}{1 \text{ N}} \right) = 0.523 \text{ m/s}^2$$

Note that thrust and thus the acceleration of the skater is constant. The velocity of the skater and the distance traveled in 5 s are

$$V_{\text{skater}} = at = (0.523 \text{ m/s}^2)(5 \text{ s}) = \mathbf{2.62 \text{ m/s}}$$

$$x = \frac{1}{2} at^2 = \frac{1}{2} (0.523 \text{ m/s}^2)(5 \text{ s})^2 = \mathbf{6.54 \text{ m}}$$

(b) The time it will take to move 5 m and the velocity at that moment are

$$x = \frac{1}{2} at^2 \quad \rightarrow \quad t = \sqrt{\frac{2x}{a}} = \sqrt{\frac{2(5 \text{ m})}{0.523 \text{ m/s}^2}} = \mathbf{4.4 \text{ s}}$$

$$V_{\text{skater}} = at = (0.523 \text{ m/s}^2)(4.4 \text{ s}) = \mathbf{2.3 \text{ m/s}}$$

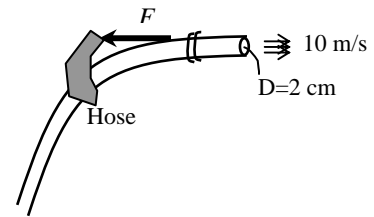

**Discussion** In reality, the velocity of the skater will be lower because of friction on ice and the resistance of the hose to follow the skater. Also, in the  $\beta \dot{m}V$  expressions,  $V$  is the fluid stream speed relative to a fixed point. Therefore, the correct expression for thrust is  $F = \dot{m}(V_{\text{jet}} - V_{\text{skater}})$ , and the analysis above is valid only when the skater speed is low relative to the jet speed. An exact analysis would result in a differential equation.

## 6-80

**Solution** A water jet hits a stationary cone, such that the flow is diverted equally in all directions at  $45^\circ$ . The force required to hold the cone in place against the water stream is to be determined.

**Assumptions** **1** The flow is steady and incompressible. **2** The water jet is exposed to the atmosphere, and thus the pressure of the water jet before and after the split is the atmospheric pressure which is disregarded since it acts on all surfaces. **3** The gravitational effects are disregarded. **4** Jet flow is nearly uniform and thus the momentum-flux correction factor can be taken to be unity,  $\beta \cong 1$ .

**Properties** We take the density of water to be  $1000 \text{ kg/m}^3$ .

**Analysis** The mass flow rate of water jet is

$$\dot{m} = \rho \dot{V} = \rho AV = \rho \frac{\pi D^2}{4} V = (1000 \text{ kg/m}^3) \frac{\pi (0.05 \text{ m})^2}{4} (30 \text{ m/s}) = 58.90 \text{ kg/s}$$

We take the diverting section of water jet, including the cone as the control volume, and designate the entrance by 1 and the outlet after divergence by 2. We also designate the horizontal coordinate by  $x$  with the direction of flow as being the positive direction and the vertical coordinate by  $y$ .

The momentum equation for steady flow is  $\sum \vec{F} = \sum_{\text{out}} \beta \dot{m} \vec{V} - \sum_{\text{in}} \beta \dot{m} \vec{V}$ . We let the  $x$ - and  $y$ - components of the anchoring

force of the cone be  $F_{Rx}$  and  $F_{Ry}$ , and assume them to be in the positive directions. Noting that  $V_2 = V_1 = V$  and  $\dot{m}_2 = \dot{m}_1 = \dot{m}$ , the momentum equations along the  $x$  and  $y$  axes become

$$F_{Rx} = \dot{m} V_2 \cos \theta - \dot{m} V_1 = \dot{m} V (\cos \theta - 1)$$

$$F_{Ry} = 0 \quad (\text{because of symmetry about } x \text{ axis})$$

Substituting the given values,

$$F_{Rx} = (58.90 \text{ kg/s})(30 \text{ m/s})(\cos 45^\circ - 1) \left( \frac{1 \text{ N}}{1 \text{ kg} \cdot \text{m/s}^2} \right)$$

$$= -518 \text{ N}$$

$$F_{Ry} = 0$$

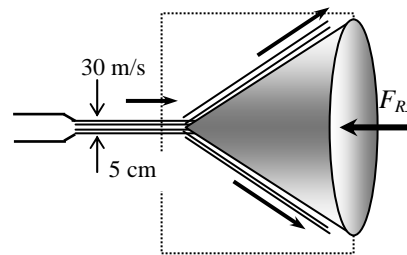

The negative value for  $F_{Rx}$  indicates that the assumed direction is wrong, and should be reversed. Therefore, a force of 518 N must be applied to the cone in the opposite direction to flow to hold it in place. No holding force is necessary in the vertical direction due to symmetry and neglecting gravitational effects.

**Discussion** In reality, the gravitational effects will cause the upper part of flow to slow down and the lower part to speed up after the split. But for short distances, these effects are negligible.

## 6-81

**Solution** Water is flowing into and discharging from a pipe U-section with a secondary discharge section normal to return flow. Net  $x$ - and  $z$ - forces at the two flanges that connect the pipes are to be determined.

**Assumptions** 1 The flow is steady and incompressible. 2 The weight of the U-turn and the water in it is negligible. 4 The momentum-flux correction factor for each inlet and outlet is given to be  $\beta = 1.03$ .

**Properties** We take the density of water to be  $1000 \text{ kg/m}^3$ .

**Analysis** The flow velocities of the 3 streams are

$$V_1 = \frac{\dot{m}_1}{\rho A_1} = \frac{\dot{m}_1}{\rho(\pi D_1^2/4)} = \frac{55 \text{ kg/s}}{(1000 \text{ kg/m}^3)[\pi(0.05 \text{ m})^2/4]} = 28.01 \text{ m/s}$$

$$V_2 = \frac{\dot{m}_2}{\rho A_2} = \frac{\dot{m}_2}{\rho(\pi D_2^2/4)} = \frac{40 \text{ kg/s}}{(1000 \text{ kg/m}^3)[\pi(0.10 \text{ m})^2/4]} = 5.093 \text{ m/s}$$

$$V_3 = \frac{\dot{m}_3}{\rho A_3} = \frac{\dot{m}_3}{\rho(\pi D_3^2/4)} = \frac{15 \text{ kg/s}}{(1000 \text{ kg/m}^3)[\pi(0.03 \text{ m})^2/4]} = 21.22 \text{ m/s}$$

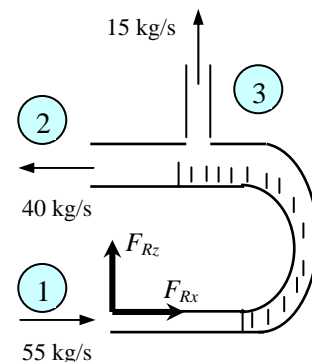

We take the entire U-section as the control volume. We designate the horizontal coordinate by  $x$  with the direction of incoming flow as being the positive direction and the vertical coordinate by  $z$ . The momentum equation for steady flow is  $\sum \vec{F} = \sum_{\text{out}} \beta \dot{m} \vec{V} - \sum_{\text{in}} \beta \dot{m} \vec{V}$ . We let the  $x$ - and  $z$ - components of the anchoring force of the cone be  $F_{Rx}$  and  $F_{Rz}$ , and

assume them to be in the positive directions. Then the momentum equations along the  $x$  and  $z$  axes become

$$F_{Rx} + P_1 A_1 + P_2 A_2 = \beta \dot{m}_2 (-V_2) - \beta \dot{m}_1 V_1 \quad \rightarrow \quad F_{Rx} = -P_1 A_1 - P_2 A_2 - \beta(\dot{m}_2 V_2 + \dot{m}_1 V_1)$$

$$F_{Rz} + 0 = \dot{m}_3 V_3 - 0 \quad \rightarrow \quad F_{Rz} = \beta \dot{m}_3 V_3$$

Substituting the given values,

$$\begin{aligned} F_{Rx} &= -[(200 - 100) \text{ kN/m}^2] \frac{\pi(0.05 \text{ m})^2}{4} - [(150 - 100) \text{ kN/m}^2] \frac{\pi(0.10 \text{ m})^2}{4} \\ &\quad - 1.03 \left[ (40 \text{ kg/s})(5.093 \text{ m/s}) \left( \frac{1 \text{ kN}}{1000 \text{ kg} \cdot \text{m/s}^2} \right) + (55 \text{ kg/s})(28.01 \text{ m/s}) \left( \frac{1 \text{ kN}}{1000 \text{ kg} \cdot \text{m/s}^2} \right) \right] \\ &= -2.386 \text{ kN} \cong \mathbf{-2390 \text{ N}} \end{aligned}$$

$$F_{Rz} = 1.03(15 \text{ kg/s})(21.22 \text{ m/s}) \left( \frac{1 \text{ N}}{1 \text{ kg} \cdot \text{m/s}^2} \right) = 327.8 \text{ N} \cong \mathbf{328 \text{ N}}$$

The negative value for  $F_{Rx}$  indicates the assumed direction is wrong, and should be reversed. Therefore, a force of 2390 N acts on the flanges in the opposite direction. A vertical force of 328 N acts on the flange in the vertical direction.

**Discussion** To assess the significance of gravity forces, we estimate the weight of the weight of water in the U-turn and compare it to the vertical force. Assuming the length of the U-turn to be 0.5 m and the average diameter to be 7.5 cm, the mass of the water becomes

$$m = \rho V = \rho AL = \rho \frac{\pi D^2}{4} L = (1000 \text{ kg/m}^3) \frac{\pi(0.075 \text{ m})^2}{4} (0.5 \text{ m}) = 2.2 \text{ kg}$$

whose weight is  $2.2 \times 9.81 = 22 \text{ N}$ , which is much less than 328, but still significant. Therefore, disregarding the gravitational effects is a reasonable assumption if great accuracy is not required.

## 6-82

**Solution** Indiana Jones is to ascend a building by building a platform, and mounting four water nozzles pointing down at each corner. The minimum water jet velocity needed to raise the system, the time it will take to rise to the top of the building and the velocity of the system at that moment, the additional rise when the water is shut off, and the time he has to jump from the platform to the roof are to be determined.

**Assumptions** 1 The air resistance is negligible. 2 The flow of water is steady and one-dimensional (but the motion of platform is unsteady). 3 The platform is still initially at  $t = 0$ . 4 Jet flow is nearly uniform and thus the momentum-flux correction factor can be taken to be unity,  $\beta \cong 1$ .

**Properties** We take the density of water to be  $1000 \text{ kg/m}^3$ .

**Analysis** (a) The total mass flow rate of water through the 4 hoses and the total weight of the platform are

$$\dot{m} = \rho AV = 4\rho \frac{\pi D^2}{4} V = 4(1000 \text{ kg/m}^3) \frac{\pi(0.04 \text{ m})^2}{4} (18 \text{ m/s}) = 90.4779 \text{ kg/s}$$

$$W = mg = (150 \text{ kg})(9.81 \text{ m/s}^2) \left( \frac{1 \text{ N}}{1 \text{ kg} \cdot \text{m/s}^2} \right) = 1471.5 \text{ N}$$

We take the platform as the system. The momentum equation for steady flow is  $\sum \vec{F} = \sum_{\text{out}} \beta \dot{m} \vec{V} - \sum_{\text{in}} \beta \dot{m} \vec{V}$ . The minimum water jet velocity needed to raise the platform is determined by setting the net force acting on the platform equal to zero,

$$-W = \dot{m}(-V_{\min}) - 0 \quad \rightarrow \quad W = \dot{m}V_{\min} = \rho AV_{\min} V_{\min} = 4\rho \frac{\pi D^2}{4} V_{\min}^2$$

Solving for  $V_{\min}$  and substituting,

$$V_{\min} = \sqrt{\frac{W}{\rho \pi D^2}} = \sqrt{\frac{1471.5 \text{ N}}{(1000 \text{ kg/m}^3) \pi (0.04 \text{ m})^2} \left( \frac{1 \text{ kg} \cdot \text{m/s}^2}{1 \text{ N}} \right)} = 17.1098 \text{ m/s} \cong \mathbf{17.1 \text{ m/s}}$$

(b) We let the vertical reaction force (assumed upwards) acting on the platform be  $F_{Rz}$ . Then the momentum equation in the vertical direction becomes

$$F_{Rz} - W = \dot{m}(-V) - 0 = \dot{m}V \quad \rightarrow \quad F_{Rz} = W - \dot{m}V = (1471.5 \text{ N}) - (90.4779 \frac{\text{kg}}{\text{s}}) (18 \frac{\text{m}}{\text{s}}) \left( \frac{1 \text{ kg} \cdot \text{m/s}^2}{1 \text{ N}} \right) = -157.101 \text{ N}$$

The upward thrust acting on the platform is equal and opposite to this reaction force, and thus  $F = 156.6 \text{ N}$ . Then the acceleration and the ascending time to rise 10 m and the velocity at that moment become

$$a = \frac{F}{m} = \frac{157.101 \text{ N}}{150 \text{ kg}} \left( \frac{1 \text{ kg} \cdot \text{m/s}^2}{1 \text{ N}} \right) = 1.0473 \text{ m/s}^2$$

$$x = \frac{1}{2} at^2 \quad \rightarrow \quad t = \sqrt{\frac{2x}{a}} = \sqrt{\frac{2(10 \text{ m})}{1.0473 \text{ m/s}^2}} = 4.36989 \text{ s} \cong \mathbf{4.37 \text{ s}}$$

and

$$V = at = (1.0473 \text{ m/s}^2)(4.36989 \text{ s}) = 4.5766 \text{ m/s}$$

(c) When the water is shut off at 10 m height (where the velocity is 4.57 m/s), the platform will decelerate under the influence of gravity, and the time it takes to come to a stop and the additional rise above 10 m become

$$V = V_0 - gt = 0 \quad \rightarrow \quad t = \frac{V_0}{g} = \frac{4.5766 \text{ m/s}}{9.81 \text{ m/s}^2} = 0.46652 \text{ s}$$

$$z = V_0 t - \frac{1}{2} gt^2 = (4.5766 \text{ m/s})(0.46652 \text{ s}) - \frac{1}{2} (9.81 \text{ m/s}^2)(0.46652 \text{ s})^2 = 1.0675 \text{ m} \cong \mathbf{1.07 \text{ m}}$$

Therefore, Jones has  $2 \times 0.46652 = 0.93304 \approx \mathbf{0.933 \text{ s}}$  to jump off from the platform to the roof since it takes another 0.466 s for the platform to descend to the 10 m level.

**Discussion** Like most stunts in the Indiana Jones movies, this would not be practical in reality.

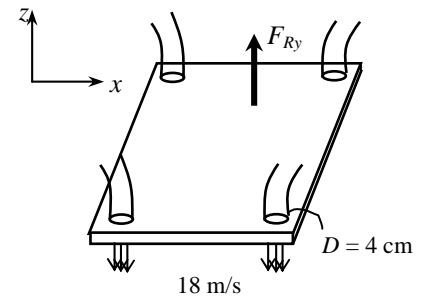

## 6-83E

**Solution** A box-enclosed fan is faced down so the air blast is directed downwards, and it is to be hovered by increasing the blade rpm. The required blade rpm, air outlet velocity, the volumetric flow rate, and the minimum mechanical power are to be determined.

**Assumptions** **1** The flow of air is steady and incompressible. **2** The air leaves the blades at a uniform velocity at atmospheric pressure, and thus the momentum-flux correction factor can be taken to be unity,  $\beta \cong 1$ . **3** Air approaches the blades from the top through a large area at atmospheric pressure with negligible velocity. **4** The frictional effects are negligible, and thus the entire mechanical power input is converted to kinetic energy of air (no conversion to thermal energy through frictional effects). **5** The change in air pressure with elevation is negligible because of the low density of air. **6** There is no acceleration of the fan, and thus the lift generated is equal to the total weight.

**Properties** The density of air is given to be  $0.078 \text{ lbm/ft}^3$ .

**Analysis** (a) We take the control volume to be a vertical hyperbolic cylinder bounded by streamlines on the sides with air entering through the large cross-section (section 1) at the top and the fan located at the narrow cross-section at the bottom (section 2), and let its centerline be the  $z$  axis with upwards being the positive direction.

The momentum equation for steady flow is  $\sum \vec{F} = \sum_{\text{out}} \beta \dot{m} \vec{V} - \sum_{\text{in}} \beta \dot{m} \vec{V}$ . Noting that the only force acting on the control volume is the total weight  $W$  and it acts in the negative  $z$  direction, the momentum equation along the  $z$  axis gives

$$-W = \dot{m}(-V_2) - 0 \quad \rightarrow \quad W = \dot{m}V_2 = (\rho AV_2)V_2 = \rho AV_2^2 \quad \rightarrow \quad V_2 = \sqrt{\frac{W}{\rho A}}$$

where  $A$  is the blade span area,

$$A = \pi D^2 / 4 = \pi (3 \text{ ft})^2 / 4 = 7.069 \text{ ft}^2$$

Then the discharge velocity to produce 5 lbf of upward force becomes

$$V_2 = \sqrt{\frac{5 \text{ lbf}}{(0.078 \text{ lbm/ft}^3)(7.069 \text{ ft}^2)}} \left( \frac{32.2 \text{ lbm} \cdot \text{ft/s}^2}{1 \text{ lbf}} \right) = 17.1 \text{ ft/s}$$

(b) The volume flow rate and the mass flow rate of air are determined from their definitions,

$$\dot{V} = AV_2 = (7.069 \text{ ft}^2)(17.1 \text{ ft/s}) = 121 \text{ ft}^3/\text{s}$$

$$\dot{m} = \rho \dot{V} = (0.078 \text{ lbm/ft}^3)(121 \text{ ft}^3/\text{s}) = 9.43 \text{ lbm/s}$$

(c) Noting that  $P_1 = P_2 = P_{\text{atm}}$ ,  $V_1 \cong 0$ , the elevation effects are negligible, and the frictional effects are disregarded, the energy equation for the selected control volume reduces to

$$\dot{m} \left( \frac{P_1}{\rho} + \frac{V_1^2}{2} + gz_1 \right) + \dot{W}_{\text{pump,u}} = \dot{m} \left( \frac{P_2}{\rho} + \frac{V_2^2}{2} + gz_2 \right) + \dot{W}_{\text{turbine}} + \dot{E}_{\text{mech,loss}} \quad \rightarrow \quad \dot{W}_{\text{fan,u}} = \dot{m} \frac{V_2^2}{2}$$

Substituting,

$$\dot{W}_{\text{fan,u}} = \dot{m} \frac{V_2^2}{2} = (9.43 \text{ lbm/s}) \frac{(18.0 \text{ ft/s})^2}{2} \left( \frac{1 \text{ lbf}}{32.2 \text{ lbm} \cdot \text{ft/s}^2} \right) \left( \frac{1 \text{ W}}{0.73756 \text{ lbf} \cdot \text{ft/s}} \right) = 64.3 \text{ W}$$

Therefore, the minimum mechanical power that must be supplied to the air stream is 64.3 W.

**Discussion** The actual power input to the fan will be considerably larger than the calculated power input because of the fan inefficiency in converting mechanical work to kinetic energy.

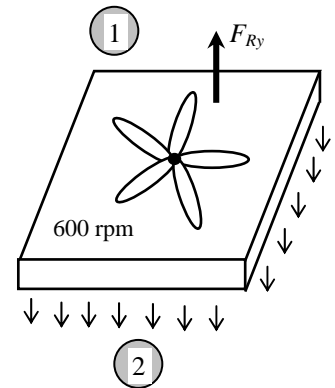

## 6-84

**Solution** A plate is maintained in a horizontal position by frictionless vertical guide rails. The underside of the plate is subjected to a water jet. The minimum mass flow rate  $\dot{m}_{\min}$  to just levitate the plate is to be determined, and a relation is to be obtained for the steady state upward velocity. Also, the integral that relates velocity to time when the water is first turned on is to be obtained.

**Assumptions** 1 The flow of water is steady and one-dimensional. 2 The water jet splatters in the plane of the plate. 3 The vertical guide rails are frictionless. 4 Times are short, so the velocity of the rising jet can be considered to remain constant with height. 5 At time  $t = 0$ , the plate is at rest. 6 Jet flow is nearly uniform and thus the momentum-flux correction factor can be taken to be unity,  $\beta \cong 1$ .

**Analysis** (a) We take the plate as the system. The momentum equation for steady flow is  $\sum \vec{F} = \sum_{\text{out}} \beta \dot{m} \vec{V} - \sum_{\text{in}} \beta \dot{m} \vec{V}$ . Noting that  $\dot{m} = \rho A V_J$  where  $A$  is the cross-sectional area of the water jet and  $W = m_p g$ , the minimum mass flow rate of water needed to raise the plate is determined by setting the net force acting on the plate equal to zero,

$$-W = 0 - \dot{m}_{\min} V_J \quad \rightarrow \quad W = \dot{m}_{\min} V_J \quad \rightarrow \quad m_p g = \dot{m}_{\min} (\dot{m}_{\min} / A V_J) \quad \rightarrow \quad \dot{m}_{\min} = \sqrt{\rho A m_p g}$$

For  $\dot{m} > \dot{m}_{\min}$ , a relation for the steady state upward velocity  $V$  is obtained setting the upward impulse applied by water jet to the weight of the plate (during steady motion, the plate velocity  $V$  is constant, and the velocity of water jet relative to plate is  $V_J - V$ ),

$$W = \dot{m}(V_J - V) \quad \rightarrow \quad m_p g = \rho A (V_J - V)^2 \quad \rightarrow \quad V_J - V = \sqrt{\frac{m_p g}{\rho A}} \quad \rightarrow \quad V = \frac{\dot{m}}{\rho A} - \sqrt{\frac{m_p g}{\rho A}}$$

(b) At time  $t = 0$  the plate is at rest ( $V = 0$ ), and it is subjected to water jet with  $\dot{m} > \dot{m}_{\min}$  and thus the net force acting on it is greater than the weight of the plate, and the difference between the jet impulse and the weight will accelerate the plate upwards. Therefore, Newton's 2<sup>nd</sup> law  $F = ma = m dV/dt$  in this case can be expressed as

$$\dot{m}(V_J - V) - W = m_p a \quad \rightarrow \quad \rho A (V_J - V)^2 - m_p g = m_p \frac{dV}{dt}$$

Separating the variables and integrating from  $t = 0$  when  $V = 0$  to  $t = t$  when  $V = V$  gives the desired integral,

$$\int_0^V \frac{m_p dV}{\rho A (V_J - V)^2 - m_p g} = \int_{t=0}^t dt \quad \rightarrow \quad t = \int_0^V \frac{m_p dV}{\rho A (V_J - V)^2 - m_p g}$$

**Discussion** This integral can be performed with the help of integral tables. But the relation obtained will be implicit in  $V$ .

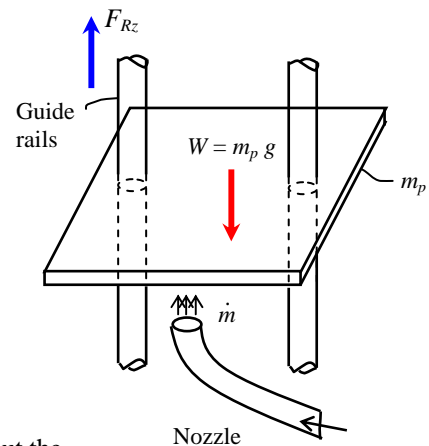



## 6-85

**Solution** A walnut is to be cracked by dropping it from a certain height to a hard surface. The minimum height required is to be determined.

**Assumptions** 1 The force remains constant during the cracking period of the walnut. 2 The air resistance is negligible.

**Analysis** We take the  $x$  axis as the upward vertical direction. Newton's 2<sup>nd</sup> law  $F = ma = m dV/dt$  can be expressed as

$$F\Delta t = m\Delta V = m(V_{\text{strike}} - V_{\text{final}}) \rightarrow V_{\text{strike}} = \frac{F\Delta t}{m}$$

since the force remains constant and the final velocity is zero. Substituting,

$$V_{\text{strike}} = \frac{F\Delta t}{m} = \frac{(200 \text{ N})(0.002 \text{ s})}{0.050 \text{ kg}} \left( \frac{1 \text{ kg} \cdot \text{m/s}^2}{1 \text{ N}} \right) = 8 \text{ m/s}$$

The elevation that will result at this value of velocity can be determined from the conservation of energy principle (in this case potential energy being converted to kinetic energy) to be

$$pe_{\text{initial}} = ke_{\text{final}} \rightarrow mgh = \frac{1}{2} mV_{\text{strike}}^2 \rightarrow h = \frac{V_{\text{strike}}^2}{2g}$$

Substituting, the required height at which the walnut needs to be dropped becomes

$$h = \frac{V_{\text{strike}}^2}{2g} = \frac{(8 \text{ m/s})^2}{2(9.81 \text{ m/s}^2)} = \mathbf{3.26 \text{ m}}$$

**Discussion** Note that a greater height will be required in reality because of air friction.

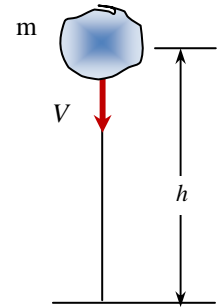

## 6-86

**Solution** A vertical water jet strikes a horizontal stationary plate normally. The maximum weight of the plate that can be supported by the water jet at a specified height is to be determined.

**Assumptions** 1 The flow of water at the nozzle outlet is steady and incompressible. 2 The water splatters in directions normal to the approach direction of the water jet. 3 The water jet is exposed to the atmosphere, and thus the pressure of the water jet and the splattered water leaving the control volume is atmospheric pressure. 4 Friction between the water and air is negligible. 5 The effect of the momentum-flux correction factor is negligible, and thus  $\beta \cong 1$  for the jet.

**Properties** We take the density of water to be  $1000 \text{ kg/m}^3$ .

**Analysis** We take the  $x$  axis as the upward vertical direction. We also take point 1 at the point where the water jet leaves the nozzle, and point 2 at the point where the jet strikes the flat plate. Noting that water jet is exposed to the atmosphere, we have  $P_1 = P_2 = P_{\text{atm}}$ . Also,  $z_1 = 0$  and  $z_2 = h$ . Then the Bernoulli Equation simplifies to

$$\frac{P_1}{\rho g} + \frac{V_1^2}{2g} + z_1 = \frac{P_2}{\rho g} + \frac{V_2^2}{2g} + z_2 \rightarrow 0 + \frac{V_1^2}{2g} + 0 = 0 + \frac{V_2^2}{2g} + h \rightarrow V_2 = \sqrt{V_1^2 - 2gh}$$

Substituting, the jet velocity when the jet strikes the flat plate is determined to be

$$V_2 = \sqrt{(15 \text{ m/s})^2 - 2(9.81 \text{ m/s}^2)(2 \text{ m})} = 13.63 \text{ m/s}$$

The mass flow rate of water is

$$\dot{m} = \rho \dot{V} = \rho A_c V = \rho \frac{\pi D^2}{4} V = (1000 \text{ kg/m}^3) \frac{\pi (0.07 \text{ m})^2}{4} (15 \text{ m/s}) = 57.73 \text{ kg/s}$$

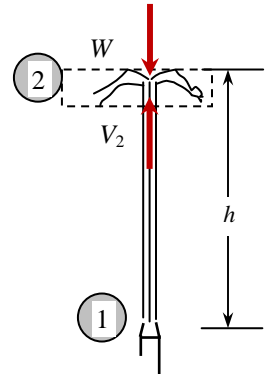

We take the thin region below the flat plate as the control volume such that it cuts through the incoming water jet. The weight  $W$  of the flat plate acts downward as a vertical force on the CV. Noting that water jet splashes out horizontally after it strikes the plate, the momentum equation for steady flow in the  $x$  (flow) direction reduces to

$$\sum \vec{F} = \sum_{\text{out}} \beta \dot{m} \vec{V} - \sum_{\text{in}} \beta \dot{m} \vec{V} \rightarrow -W = -\dot{m} V_2 \rightarrow W = \dot{m} V_2$$

Substituting, the weight of the flat plate is determined to be

$$W = (57.73 \text{ kg/s})(13.36 \text{ m/s}) \left( \frac{1 \text{ N}}{1 \text{ kg} \cdot \text{m/s}^2} \right) = \mathbf{771 \text{ N}}$$

**Discussion** Note that this weight corresponds to a plate mass of  $771/9.81 = 78.5 \text{ kg}$  of mass. Also, a smaller mass will be held in balance at a greater height and a larger mass at a smaller height.

## 6-87

**Solution** A vertical water jet strikes a horizontal stationary plate normally. The maximum weight of the plate that can be supported by the water jet at a specified height is to be determined.

**Assumptions** 1 The flow of water at the nozzle outlet is steady and incompressible. 2 The water splatters in directions normal to the approach direction of the water jet. 3 The water jet is exposed to the atmosphere, and thus the pressure of the water jet and the splattered water leaving the control volume is atmospheric pressure. 4 Friction between the water and air is negligible. 5 The effect of the momentum-flux correction factor is negligible, and thus  $\beta \cong 1$  for the jet.

**Properties** We take the density of water to be  $1000 \text{ kg/m}^3$ .

**Analysis** We take the  $x$  axis as the upward vertical direction. We also take point 1 at the point where the water jet leaves the nozzle, and point 2 at the point where the jet strikes the flat plate. Noting that water jet is exposed to the atmosphere, we have  $P_1 = P_2 = P_{\text{atm}}$ . Also,  $z_1 = 0$  and  $z_2 = h$ . Then the Bernoulli Equation simplifies to

$$\frac{P_1}{\rho g} + \frac{V_1^2}{2g} + z_1 = \frac{P_2}{\rho g} + \frac{V_2^2}{2g} + z_2 \rightarrow 0 + \frac{V_1^2}{2g} + 0 = 0 + \frac{V_2^2}{2g} + h \rightarrow V_2 = \sqrt{V_1^2 - 2gh}$$

Substituting, the jet velocity when the jet strikes the flat plate is determined to be

$$V_2 = \sqrt{(15 \text{ m/s})^2 - 2(9.81 \text{ m/s}^2)(8 \text{ m})} = 8.249 \text{ m/s}$$

The mass flow rate of water is

$$\dot{m} = \rho \dot{V} = \rho A_c V = \rho \frac{\pi D^2}{4} V = (1000 \text{ kg/m}^3) \frac{\pi (0.07 \text{ m})^2}{4} (15 \text{ m/s}) = 57.73 \text{ kg/s}$$

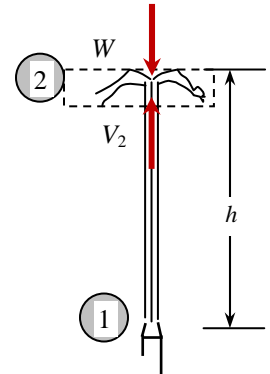

We take the thin region below the flat plate as the control volume such that it cuts through the incoming water jet. The weight  $W$  of the flat plate acts downward as a vertical force on the CV. Noting that water jet splashes out horizontally after it strikes the plate, the momentum equation for steady flow in the  $x$  (flow) direction reduces to

$$\sum \vec{F} = \sum_{\text{out}} \beta \dot{m} \vec{V} - \sum_{\text{in}} \beta \dot{m} \vec{V} \rightarrow -W = -\dot{m} V_2 \rightarrow W = \dot{m} V_2$$

Substituting, the weight of the flat plate is determined to be

$$W = (57.73 \text{ kg/s})(8.249 \text{ m/s}) \left( \frac{1 \text{ N}}{1 \text{ kg} \cdot \text{m/s}^2} \right) = \mathbf{476 \text{ N}}$$

**Discussion** Note that this weight corresponds to a plate mass of  $476/9.81 = 48.5 \text{ kg}$  of mass. Also, a smaller mass will be held in balance at a greater height and a larger mass at a smaller height.

## 6-88

**Solution** It is to be shown that the force exerted by a liquid jet of velocity  $V$  on a stationary nozzle is proportional to  $V^2$ , or alternatively, to  $\dot{m}^2$ .

**Assumptions** 1 The flow is steady and incompressible. 2 The nozzle is given to be stationary. 3 The nozzle involves a  $90^\circ$  turn and thus the incoming and outgoing flow streams are normal to each other. 4 The water is discharged to the atmosphere, and thus the gage pressure at the outlet is zero.

**Analysis** We take the nozzle as the control volume, and the flow direction at the outlet as the  $x$  axis. Note that the nozzle makes a  $90^\circ$  turn, and thus it does not contribute to any pressure force or momentum flux term at the inlet in the  $x$  direction. Noting that  $\dot{m} = \rho AV$  where  $A$  is the nozzle outlet area and  $V$  is the average nozzle outlet velocity, the momentum equation for steady flow in the  $x$  direction reduces to

$$\sum \vec{F} = \sum_{\text{out}} \beta \dot{m} \vec{V} - \sum_{\text{in}} \beta \dot{m} \vec{V} \quad \rightarrow \quad F_{Rx} = \beta \dot{m}_{\text{out}} V_{\text{out}} = \beta \dot{m} V$$

where  $F_{Rx}$  is the reaction force on the nozzle due to liquid jet at the nozzle outlet. Then,

$$\dot{m} = \rho AV \quad \rightarrow \quad F_{Rx} = \beta \dot{m} V = \beta \rho A V V = \beta \rho A V^2 \quad \text{or} \quad \boxed{F_{Rx} = \beta \dot{m} V = \beta \dot{m} \frac{\dot{m}}{\rho A} = \beta \frac{\dot{m}^2}{\rho A}}$$

Therefore, **the force exerted by a liquid jet of velocity  $V$  on this stationary nozzle is proportional to  $V^2$ , or alternatively, to  $\dot{m}^2$ .**

**Discussion** If there were not a  $90^\circ$  turn, we would need to take into account the momentum flux and pressure contributions at the inlet.

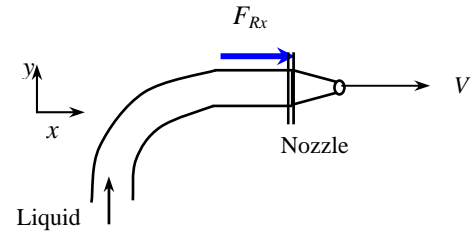

## 6-89

**Solution** A parachute slows a soldier from his terminal velocity  $V_T$  to his landing velocity of  $V_F$ . A relation is to be developed for the soldier's velocity after he opens the parachute at time  $t = 0$ .

**Assumptions** **1** The air resistance is proportional to the velocity squared (i.e.  $F = -kV^2$ ). **2** The variation of the air properties with altitude is negligible. **3** The buoyancy force applied by air to the person (and the parachute) is negligible because of the small volume occupied and the low density of air. **4** The final velocity of the soldier is equal to its terminal velocity with his parachute open.

**Analysis** The terminal velocity of a free falling object is reached when the air resistance (or air drag) equals the weight of the object, less the buoyancy force applied by the fluid, which is negligible in this case,

$$F_{\text{air resistance}} = W \rightarrow kV_F^2 = mg \rightarrow k = \frac{mg}{V_F^2}$$

This is the desired relation for the constant of proportionality  $k$ . When the parachute is deployed and the soldier starts to decelerate, the net downward force acting on him is his weight less the air resistance,

$$F_{\text{net}} = W - F_{\text{air resistance}} = mg - kV^2 = mg - \frac{mg}{V_F^2} V^2 = mg \left( 1 - \frac{V^2}{V_F^2} \right)$$

Substituting it into Newton's 2<sup>nd</sup> law relation  $F_{\text{net}} = ma = m \frac{dV}{dt}$  gives

$$mg \left( 1 - \frac{V^2}{V_F^2} \right) = m \frac{dV}{dt}$$

Canceling  $m$  and separating variables, and integrating from  $t = 0$  when  $V = V_T$  to  $t = t$  when  $V = V$  gives

$$\frac{dV}{1 - V^2/V_F^2} = g dt \rightarrow \int_{V_T}^V \frac{dV}{V_F^2 - V^2} = \frac{g}{V_F^2} \int_0^t dt$$

Using  $\int \frac{dx}{a^2 - x^2} = \frac{1}{2a} \ln \frac{a+x}{a-x}$  from integral tables and applying the integration limits,

$$\frac{1}{2V_F} \left( \ln \frac{V_F + V}{V_F - V} - \ln \frac{V_F + V_T}{V_F - V_T} \right) = \frac{gt}{V_F^2}$$

Rearranging, the velocity can be expressed explicitly as a function of time as

$$V = V_F \frac{V_T + V_F + (V_T - V_F)e^{-2gt/V_F}}{V_T + V_F - (V_T - V_F)e^{-2gt/V_F}}$$

**Discussion** Note that as  $t \rightarrow \infty$ , the velocity approaches the landing velocity of  $V_F$ , as expected.

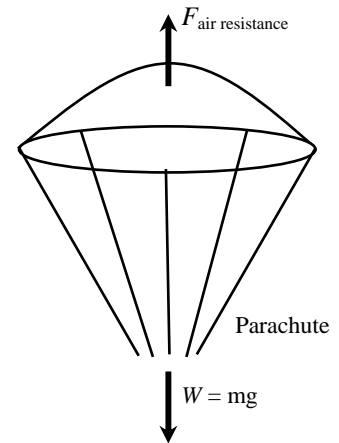

## 6-90

**Solution** An empty cart is to be driven by a horizontal water jet that enters from a hole at the rear of the cart. A relation is to be developed for cart velocity versus time.

**Assumptions** **1** The flow of water is steady, one-dimensional, incompressible, and horizontal. **2** All the water which enters the cart is retained. **3** The path of the cart is level and frictionless. **4** The cart is initially empty and stationary, and thus  $V = 0$  at time  $t = 0$ . **5** Friction between water jet and air is negligible, and the entire momentum of water jet is used to drive the cart with no losses. **6** Jet flow is nearly uniform and thus the momentum-flux correction factor can be taken to be unity,  $\beta \cong 1$ .

**Analysis** We note that the water jet velocity  $V_J$  is constant, but the car velocity  $V$  is variable. Noting that  $\dot{m} = \rho A(V_J - V)$  where  $A$  is the cross-sectional area of the water jet and  $V_J - V$  is the velocity of the water jet relative to the cart, the mass of water in the cart at any time  $t$  is

$$m_w = \int_0^t \dot{m} dt = \int_0^t \rho A(V_J - V) dt = \rho A V_J t - \rho A \int_0^t V dt \quad (1)$$

Also,

$$\frac{dm_w}{dt} = \dot{m} = \rho A(V_J - V)$$

We take the cart as the moving control volume. The net force acting on the cart in this case is equal to the momentum flux of the water jet.

Newton's 2<sup>nd</sup> law  $F = ma = d(mV)/dt$  in this case can be expressed as

$$F = \frac{d(m_{\text{total}}V)}{dt} \quad \text{where} \quad F = \sum_{\text{in}} \beta \dot{m} V - \sum_{\text{out}} \beta \dot{m} V = (\dot{m}V)_{\text{in}} = \dot{m}V_J = \rho A(V_J - V)V_J$$

and

$$\begin{aligned} \frac{d(m_{\text{total}}V)}{dt} &= \frac{d[(m_c + m_w)V]}{dt} = m_c \frac{dV}{dt} + \frac{d(m_w V)}{dt} = m_c \frac{dV}{dt} + m_w \frac{dV}{dt} + V \frac{dm_w}{dt} \\ &= (m_c + m_w) \frac{dV}{dt} + \rho A(V_J - V)V \end{aligned}$$

Note that in  $\beta \dot{m} V$  expressions, we used the fluid stream velocity relative to a fixed point. Substituting,

$$\rho A(V_J - V)V_J = (m_c + m_w) \frac{dV}{dt} + \rho A(V_J - V)V \quad \rightarrow \quad \rho A(V_J - V)(V_J - V) = (m_c + m_w) \frac{dV}{dt}$$

Noting that  $m_w$  is a function of  $t$  (as given by Eq. 1) and separating variables,

$$\frac{dV}{\rho A(V_J - V)^2} = \frac{dt}{m_c + m_w} \quad \rightarrow \quad \frac{dV}{\rho A(V_J - V)^2} = \frac{dt}{m_c + \rho A V_J t - \rho A \int_0^t V dt}$$

Integrating from  $t = 0$  when  $V = 0$  to  $t = t$  when  $V = V$  gives the desired integral,

$$\int_0^V \frac{dV}{\rho A(V_J - V)^2} = \int_0^t \frac{dt}{m_c + \rho A V_J t - \rho A \int_0^t V dt}$$

**Discussion** Note that the time integral involves the integral of velocity, which complicates the solution.

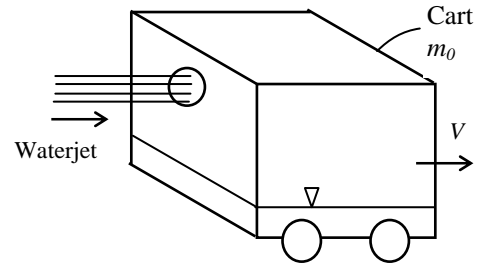

## 6-91

**Solution** Water enters the impeller of a turbine through its outer edge of diameter  $D$  with velocity  $V$  making an angle  $\alpha$  with the radial direction at a mass flow rate of  $\dot{m}$ , and leaves the impeller in the radial direction. The maximum power that can be generated is to be shown to be  $\dot{W}_{\text{shaft}} = \pi \dot{m} D V \sin \alpha$ .

**Assumptions** 1 The flow is steady in the mean. 2 Irreversible losses are negligible.

**Analysis** We take the impeller region as the control volume. The tangential velocity components at the inlet and the outlet are  $V_{1,t} = 0$  and  $V_{2,t} = V \sin \alpha$ .

Normal velocity components as well pressure acting on the inner and outer circumferential areas pass through the shaft center, and thus they do not contribute to torque. Only the tangential velocity components contribute to torque, and the application of the angular momentum equation gives

$$T_{\text{shaft}} = \dot{m}(r_2 V_{2,t} - r_1 V_{1,t}) = \dot{m} r_2 V_{2,t} - 0 = \dot{m} D (V \sin \alpha) / 2$$

The angular velocity of the propeller is  $\omega = 2\pi i$ . Then the shaft power becomes

$$\dot{W}_{\text{shaft}} = \omega T_{\text{shaft}} = 2\pi \dot{m} D (V \sin \alpha) / 2$$

Simplifying, the maximum power generated becomes  $\dot{W}_{\text{shaft}} = \pi \dot{m} D V \sin \alpha$  which is the desired relation.

**Discussion** The actual power is less than this due to irreversible losses that are not taken into account in our analysis.

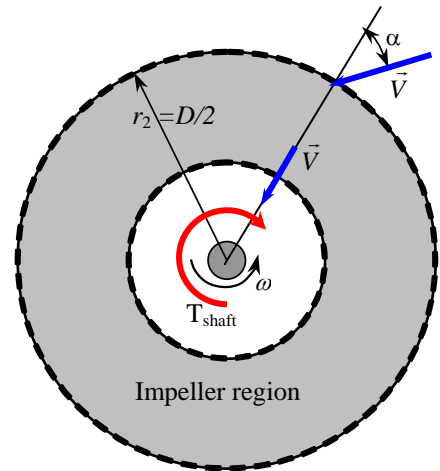

## 6-92

**Solution** A two-armed sprinkler is used to water a garden. For specified flow rate and discharge angles, the rates of rotation of the sprinkler head are to be determined.

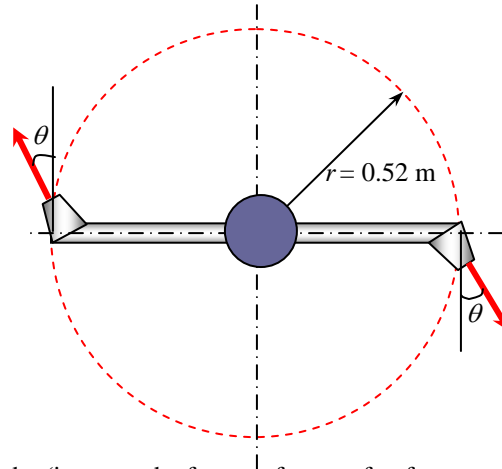

**Assumptions** 1 The flow is uniform and cyclically steady (i.e., steady from a frame of reference rotating with the sprinkler head). 2 The water is discharged to the atmosphere, and thus the gage pressure at the nozzle outlet is zero. 3 Frictional effects and air drag of rotating components are neglected. 4 The nozzle diameter is small compared to the moment arm, and thus we use average values of radius and velocity at the outlet.

**Properties** We take the density of water to be  $1000 \text{ kg/m}^3 = 1 \text{ kg/L}$ .

**Analysis** We take the disk that encloses the sprinkler arms as the control volume, which is a stationary control volume. The conservation of mass equation for this steady flow system is  $\dot{m}_1 = \dot{m}_2 = \dot{m}$ . Noting that the two nozzles are identical, we have  $\dot{m}_{\text{nozzle}} = \dot{m}/2$  or  $\dot{V}_{\text{nozzle}} = \dot{V}_{\text{total}}/2$  since the density of water is constant. The average jet outlet velocity relative to the nozzle is

$$V_{\text{jet}} = \frac{\dot{V}_{\text{nozzle}}}{A_{\text{jet}}} = \frac{75 \text{ L/s}}{2[\pi(0.02 \text{ m})^2/4]} \left( \frac{1 \text{ m}^3}{1000 \text{ L}} \right) = 119.4 \text{ m/s}$$

The angular momentum equation can be expressed as  $\sum M = \sum_{\text{out}} r\dot{m}V - \sum_{\text{in}} r\dot{m}V$ . Noting that there are no external moments acting, the angular momentum equation about the axis of rotation becomes

$$0 = -2r\dot{m}_{\text{nozzle}}V_r \cos\theta \quad \rightarrow \quad V_r = 0 \quad \rightarrow \quad V_{\text{jet,t}} - V_{\text{nozzle}} = 0$$

Noting that the tangential component of jet velocity is  $V_{\text{jet,t}} = V_{\text{jet}} \cos\theta$ , we have

$$V_{\text{nozzle}} = V_{\text{jet}} \cos\theta = (119.4 \text{ m/s})\cos\theta$$

Also noting that  $V_{\text{nozzle}} = \omega r = 2\pi\dot{n}r$ , and angular speed and the rate of rotation of sprinkler head become

$$1) \theta = 0^\circ: \omega = \frac{V_{\text{nozzle}}}{r} = \frac{(119.4 \text{ m/s})\cos 0^\circ}{0.52 \text{ m}} = \mathbf{230 \text{ rad/s}} \quad \text{and} \quad \dot{n} = \frac{\omega}{2\pi} = \frac{230 \text{ rad/s}}{2\pi} \left( \frac{60 \text{ s}}{1 \text{ min}} \right) = \mathbf{2193 \text{ rpm}}$$

$$2) \theta = 30^\circ: \omega = \frac{V_{\text{nozzle}}}{r} = \frac{(119.4 \text{ m/s})\cos 30^\circ}{0.52 \text{ m}} = \mathbf{199 \text{ rad/s}} \quad \text{and} \quad \dot{n} = \frac{\omega}{2\pi} = \frac{199 \text{ rad/s}}{2\pi} \left( \frac{60 \text{ s}}{1 \text{ min}} \right) = \mathbf{1899 \text{ rpm}}$$

$$3) \theta = 60^\circ: \omega = \frac{V_{\text{nozzle}}}{r} = \frac{(119.4 \text{ m/s})\cos 60^\circ}{0.52 \text{ m}} = \mathbf{115 \text{ rad/s}} \quad \text{and} \quad \dot{n} = \frac{\omega}{2\pi} = \frac{115 \text{ rad/s}}{2\pi} \left( \frac{60 \text{ s}}{1 \text{ min}} \right) = \mathbf{1096 \text{ rpm}}$$

**Discussion** Final results are given to three significant digits, as usual. The rate of rotation in reality will be lower because of frictional effects and air drag.



6-93



**Solution** The previous problem is reconsidered. The effect of discharge angle  $\theta$  on the rate of rotation  $\dot{n}$  as  $\theta$  varies from 0 to 90° in increments of 10° is to be investigated.

**Analysis** The EES Equations window is printed below, followed by the tabulated and plotted results.

```

D=0.02 "m"
r=0.45 "m"
n_nozzle=2 "number of nozzles"
Ac=pi*D^2/4
V_jet=V_dot/Ac/n_nozzle
V_nozzle=V_jet*cos(theta)
V_dot=0.060 "m3/s"
omega=V_nozzle/r
n_dot=omega*60/(2*pi)

```

Angle, $\theta$	$V_{\text{nozzle}}$ , m/s	$\omega$ rad/s	$\dot{n}$ rpm
0	95.5	212	2026
10	94.0	209	1996
20	89.7	199	1904
30	82.7	184	1755
40	73.2	163	1552
50	61.4	136	1303
60	47.7	106	1013
70	32.7	73	693
80	16.6	37	352
90	0.0	0	0

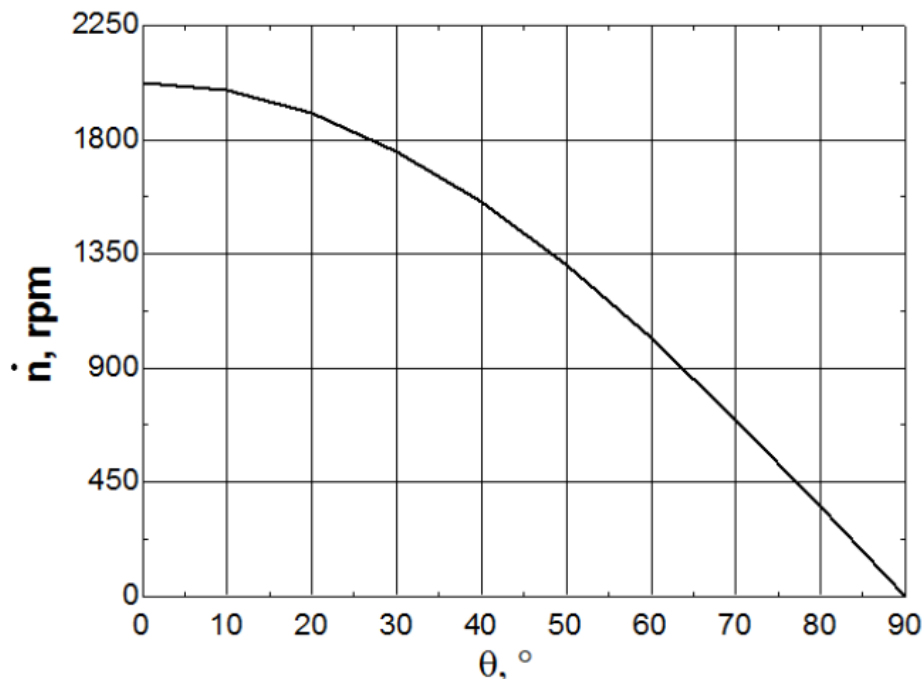

**Discussion** The maximum rpm occurs when  $\theta = 0^\circ$ , as expected, since this represents purely tangential outflow. When  $\theta = 90^\circ$ , the rpm drops to zero, as also expected, since the outflow is purely radial and therefore there is no torque to spin the sprinkler.

## 6-94

**Solution** A stationary water tank placed on wheels on a frictionless surface is propelled by a water jet that leaves the tank through a smooth hole. Relations are to be developed for the acceleration, the velocity, and the distance traveled by the tank as a function of time as water discharges.

**Assumptions** 1 The orifice has a smooth entrance, and thus the frictional losses are negligible. 2 The flow is steady, incompressible, and irrotational (so that the Bernoulli equation is applicable). 3 The surface under the wheeled tank is level and frictionless. 4 The water jet is discharged horizontally and rearward. 5 The mass of the tank and wheel assembly is negligible compared to the mass of water in the tank. 4 Jet flow is nearly uniform and thus the momentum-flux correction factor can be taken to be unity,  $\beta \cong 1$ .

**Analysis** (a) We take point 1 at the free surface of the tank, and point 2 at the outlet of the hole, which is also taken to be the reference level ( $z_2 = 0$ ) so that the water height above the hole at any time is  $z$ . Noting that the fluid velocity at the free surface is very low ( $V_1 \cong 0$ ), it is open to the atmosphere ( $P_1 = P_{\text{atm}}$ ), and water discharges into the atmosphere (and thus  $P_2 = P_{\text{atm}}$ ), the Bernoulli equation simplifies to

$$\frac{P_1}{\rho g} + \frac{V_1^2}{2g} + z_1 = \frac{P_2}{\rho g} + \frac{V_2^2}{2g} + z_2 \rightarrow z = \frac{V_J^2}{2g} + 0 \rightarrow V_J = \sqrt{2gz}$$

The discharge rate of water from the tank through the hole is

$$\dot{m} = \rho A V_J = \rho \frac{\pi D_0^2}{4} V_J = \rho \frac{\pi D_0^2}{4} \sqrt{2gz}$$

The momentum equation for steady flow is  $\sum \vec{F} = \sum_{\text{out}} \beta \dot{m} \vec{V} - \sum_{\text{in}} \beta \dot{m} \vec{V}$ . Applying it to the water tank, the horizontal force that acts on the tank is determined to be

$$F = \dot{m} V_e - 0 = \dot{m} V_J = \rho \frac{\pi D_0^2}{4} 2gz = \rho g z \frac{\pi D_0^2}{2}$$

The acceleration of the water tank is determined from Newton's 2<sup>nd</sup> law of motion  $F = ma$  where  $m$  is the mass of water in the tank,  $m = \rho V_{\text{tank}} = \rho(\pi D^2 / 4)z$ ,

$$a = \frac{F}{m} = \frac{\rho g z (\pi D_0^2 / 2)}{\rho z (\pi D^2 / 4)} \rightarrow \boxed{a = 2g \frac{D_0^2}{D^2}}$$

Note that the acceleration of the tank is constant.

(b) Noting that  $a = dV/dt$  and thus  $dV = a dt$  and acceleration  $a$  is constant, the velocity is expressed as

$$V = at \rightarrow \boxed{V = 2g \frac{D_0^2}{D^2} t}$$

(c) Noting that  $V = dx/dt$  and thus  $dx = V dt$ , the distance traveled by the water tank is determined by integration to be

$$dx = V dt \rightarrow dx = 2g \frac{D_0^2}{D^2} t dt \rightarrow \boxed{x = g \frac{D_0^2}{D^2} t^2}$$

since  $x = 0$  at  $t = 0$ .

**Discussion** In reality, the flow rate discharge velocity and thus the force acting on the water tank will be less because of the frictional losses at the hole. But these losses can be accounted for by incorporating a discharge coefficient.

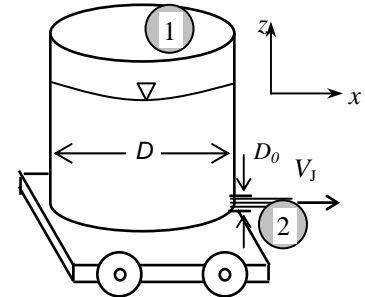

## 6-95

**Solution** The rocket of a satellite is fired in the opposite direction to motion. The thrust exerted on the satellite, the acceleration, and the velocity change are to be determined.

**Assumptions** **1** The flow of combustion gases is steady and one-dimensional during the firing period, but the motion of the satellite is unsteady. **2** There are no external forces acting on the spacecraft, and the effect of pressure force at the nozzle outlet is negligible. **3** The mass of discharged fuel is negligible relative to the mass of the spacecraft, and thus, the spacecraft may be treated as a solid body with a constant mass. **4** The nozzle is well designed such that the effect of the momentum-flux correction factor is negligible, and thus  $\beta \cong 1$ .

**Analysis** (a) For convenience, we choose an inertial reference frame that moves with the satellite at the same initial velocity. Then the velocities of fluid stream relative to an inertial reference frame become simply the velocities relative to the satellite. We take the direction of motion of the satellite as the positive direction along the  $x$ -axis. There are no external forces acting on the satellite, and its mass is essentially constant. Therefore, the satellite can be treated as a solid body with constant mass, and the momentum equation in this case is

$$\vec{F}_{\text{thrust}} = m_{\text{satellite}} \vec{a}_{\text{satellite}} = \sum_{\text{in}} \beta \dot{m} \vec{V} - \sum_{\text{out}} \beta \dot{m} \vec{V}$$

The fuel discharge rate is

$$\dot{m}_f = \frac{m_f}{\Delta t} = \frac{100 \text{ kg}}{3 \text{ s}} = 33.33 \text{ kg/s}$$

Then the thrust exerted on the satellite in the positive  $x$  direction becomes

$$F_{\text{thrust}} = 0 - \dot{m}_f V_f = -(33.33 \text{ kg/s})(-3000 \text{ m/s}) \left( \frac{1 \text{ kN}}{1000 \text{ kg} \cdot \text{m/s}^2} \right) = \mathbf{100 \text{ kN}}$$

(b) Noting that the net force acting on the satellite is thrust, the acceleration of the satellite in the direction of thrust during the first 2 s is determined to be

$$a_{\text{satellite}} = \frac{F_{\text{thrust}}}{m_{\text{satellite}}} = \frac{100 \text{ kN}}{3400 \text{ kg}} \left( \frac{1000 \text{ kg} \cdot \text{m/s}^2}{1 \text{ kN}} \right) = 29.41 \text{ m/s}^2 \cong \mathbf{29.4 \text{ m/s}^2}$$

(c) Knowing acceleration, which is constant, the velocity change of the satellite during the first 2 s is determined from the definition of acceleration  $a_{\text{satellite}} = dV_{\text{satellite}} / dt$ ,

$$\Delta V_{\text{satellite}} = a_{\text{satellite}} \Delta t = (29.41 \text{ m/s}^2)(3 \text{ s}) = \mathbf{88.2 \text{ m/s}}$$

**Discussion** Note that if this satellite were attached somewhere, it would exert a force of 100 kN (equivalent to the weight of 10 tons of mass) to its support. This can be verified by taking the satellite as the system and applying the momentum equation.

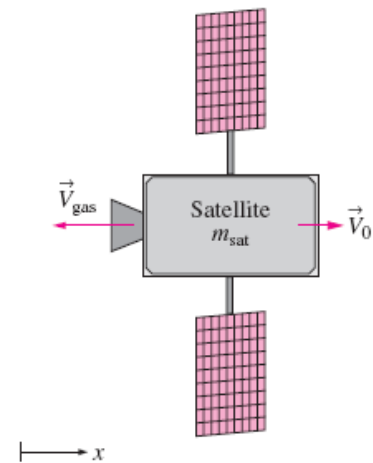

## 6-96

**Solution** Water enters a centrifugal pump axially at a specified rate and velocity, and leaves at an angle from the axial direction. The force acting on the shaft in the axial direction is to be determined.

**Assumptions** **1** The flow is steady and incompressible. **2** The forces acting on the piping system in the horizontal direction are negligible. **3** The atmospheric pressure is disregarded since it acts on all surfaces. **4** Water flow is nearly uniform at the outlet and thus the momentum-flux correction factor can be taken to be unity,  $\beta \cong 1$ .

**Properties** We take the density of water to be  $1000 \text{ kg/m}^3$ .

**Analysis** From conservation of mass we have  $\dot{m}_1 = \dot{m}_2 = \dot{m}$ , and thus  $\dot{V}_1 = \dot{V}_2$  and  $A_{c1}V_1 = A_{c2}V_2$ . Noting that the discharge area is half the inlet area, the discharge velocity is twice the inlet velocity. That is,

$$A_{c1}V_2 = \frac{A_{c1}}{A_{c2}}V_1 = 2V_1 = 2(7 \text{ m/s}) = 14 \text{ m/s}$$

We take the pump as the control volume, and the inlet direction of flow as the positive direction of  $x$  axis. The linear momentum equation in this case in the  $x$  direction reduces to

$$\sum \vec{F} = \sum_{\text{out}} \beta \dot{m} \vec{V} - \sum_{\text{in}} \beta \dot{m} \vec{V} \quad \rightarrow \quad -F_{Rx} = \dot{m}V_2 \cos \theta - \dot{m}V_1 \quad \rightarrow \quad F_{Rx} = \dot{m}(V_1 - V_2 \cos \theta)$$

where the mass flow rate is

$$\dot{m} = \rho \dot{V} = (1000 \text{ kg/m}^3)(0.30 \text{ m}^3/\text{s}) = 300 \text{ kg/s}$$

Substituting the known quantities, the reaction force is determined to be

$$F_{Rx} = (300 \text{ kg/s})[(7 \text{ m/s}) - (14 \text{ m/s})\cos 75^\circ] \left( \frac{1 \text{ N}}{1 \text{ kg} \cdot \text{m/s}^2} \right) = \mathbf{1013 \text{ N}}$$

**Discussion** Note that at this angle of discharge, the bearing is not subjected to any horizontal loading. Therefore, the loading in the system can be controlled by adjusting the discharge angle.

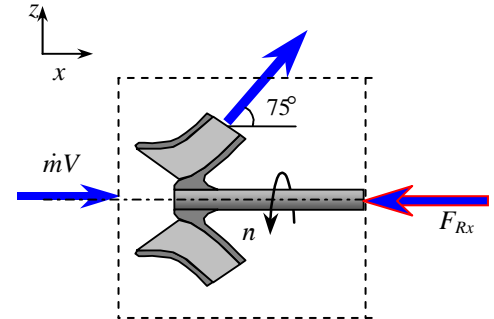

## 6-97

**Solution** Water flows through a splitter. The external force needed to hold the device fixed is to be determined.

**Assumptions** 1 The flow is steady and incompressible. 2 The water is discharged to the atmosphere, and thus the gage pressure at the outlet is zero.

**Properties** We take the density of water to be  $1000 \text{ kg/m}^3$ .

**Analysis**

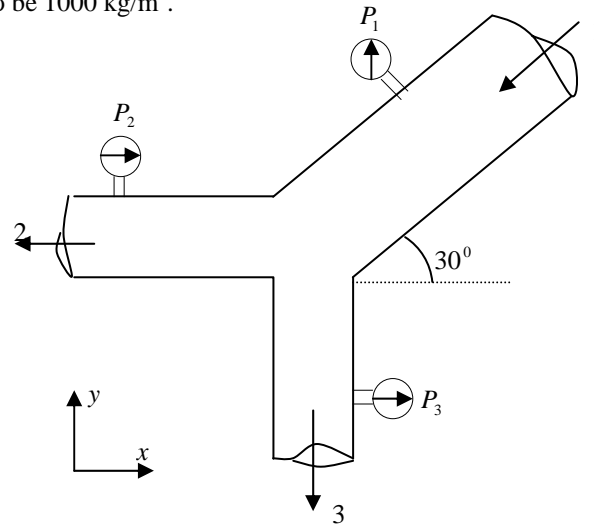

Velocities at each section are

$$V_1 = \frac{0,08}{\pi \cdot 0,12^2 / 4} = 7,07 \text{ m/s}$$

$$V_2 = \frac{0,05}{\pi \cdot 0,12^2 / 4} = 4,42 \text{ m/s}$$

$$V_3 = \frac{0,03}{\pi \cdot 0,1^2 / 4} = 3,82 \text{ m/s}$$

Applying linear momentum equation to the CV,

$$\frac{\partial}{\partial t} \int_{CV} V \rho dV + \int_{CS} \vec{V} \cdot \rho \vec{V} \cdot \vec{n} dA = \sum F$$

x-component:

$$-(V_1 \cdot \cos \theta) \rho (-V_1) A_1 + (-V_2) \rho (V_2) A_2 = -P_1 A_1 \cos \theta + P_2 A_2 + R_x$$

$$-\rho \dot{V}_1 \cos \theta V_1 - \rho \dot{V}_2 V_2 + P_1 A_1 \cos \theta - P_2 A_2 = R_x$$

$$R_x = (1000)(0,08 \cdot \cos 30)(7,07) - 1000 \times (0,05) \times (4,42) + 100000\pi \frac{0,12^2}{4} \cos 30 - 90000\pi \frac{0,12^2}{4}$$

$$R_x = 230 \text{ N}$$

y-component:

$$(-V_1 \cdot \sin \theta) \rho (-V_1) A_1 - V_3 \rho (V_3) A_3 = -P_1 A_1 \sin \theta + P_3 A_3 + R_y$$

$$R_y = \rho \dot{V}_1 V_1 \sin \theta - \rho \dot{V}_3 V_3 + P_1 A_1 \sin \theta - P_3 A_3$$

$$R_y = 1000 \times 0,08 \times 7,07 \times \sin 30 - 1000 \times 0,03 \times 3,82 + 100000\pi \frac{0,12^2}{4} - 80000 \frac{\pi 0,1^2}{4}$$

$$R_y = 671 \text{ N} \uparrow$$

The resultant force is then

$$R = \sqrt{230^2 + 671^2} = \mathbf{709 \text{ N}}$$

## 6-98

**Solution** Water is discharged from a pipe through a rectangular slit underneath of the pipe. The rate of discharge through the slit and the vertical force acting on the pipe due to this discharge process are to be determined.

**Assumptions** 1 The flow is steady and incompressible. 2 The water is discharged to the atmosphere, and thus the gage pressure at the outlet is zero.

**Properties** We take the density of water to be  $1000 \text{ kg/m}^3$ .

**Analysis**

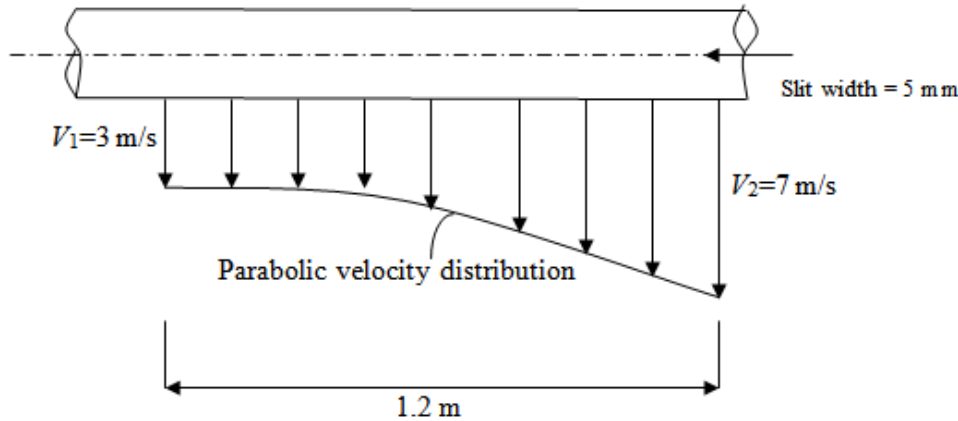

(a) From the conservation of mass,

$$\frac{\partial}{\partial t} \int \rho dV + \int_{CS} \rho \vec{V} \cdot \vec{n} dA = 0$$

$$\rho(-V_3)A_3 + \int_0^L \rho V dA = 0$$

$$V = a + bx + cx^2, \quad x=0 \quad V = V_1 = 3 \text{ m/s}, \quad a = 3 \text{ m/s}$$

$$x=0 \quad \frac{dv}{dx} = 0, \quad b + 2cx = 0, \quad b = 0$$

$$x=L, \quad V = V_2 = 7 \text{ m/s}$$

$$7 = 3 + c \cdot 1.2^2 \rightarrow c = 2.77$$

$$V(y) = 3 + 2.77x^2$$

$$-\rho \dot{V} + \int_0^L \rho (3 + 2.77x^2) dx = 0$$

$$\dot{V} = \int_0^{1.2} (3 + 2.77x^2) \times 0.01 dx = 0.005 (3x + 0.923x^3) \Big|_0^{1.2}$$

$$\dot{V} = 0.026 \text{ m}^3/\text{s}$$

(b) Momentum equations: y-component:

$$0 + \int_0^L (-V) \rho(V) dA = R_y$$

$$R_y = -\int_0^L \rho V^2 t dx = -\rho t \int_0^L (3 + 2.77x^2)^2 dx$$

$$R_y = -\rho t \int_0^L (9 + 16.62x^2 + 7.673x^4) dx$$

$$R_y = -\rho t \left[ 9x + 5.54x^3 + 1.5346x^5 \right]_0^{1.2}$$

$$R_y = -1000 \times 0.005 \times (24.19) \Rightarrow$$

$$R_y = -121 \text{ N } \downarrow$$

---

---

**Fundamentals of Engineering (FE) Exam Problems**

---

**6-99**

When determining the thrust developed by a jet engine, a wise choice of control volume is

- (a) Fixed control volume    (b) Moving control volume    (c) Deforming control volume  
(d) Moving or deforming control volume    (e) None of these

*Answer* (c) Deforming control volume

**6-100**

Consider an airplane cruising at 850 km/h to the right. If the velocity of exhaust gases is 700 km/h to the left relative to the ground, the velocity of the exhaust gases relative to the nozzle exit is

- (a) 1550 km/h    (b) 850 km/h    (c) 700 km/h    (d) 350 km/h    (e) 150 km/h

*Answer* (a) 1550 km/h

**Solution** Solved by EES Software. Solutions can be verified by copying-and-pasting the following lines on a blank EES screen. (Similar problems and their solutions can be obtained easily by modifying numerical values).

V\_airplane=850 [km/h]

V\_exhaust=-700 [km/h]

V\_r=V\_airplane-V\_exhaust



## 6-101

Consider water flow through a horizontal, short garden hose at a rate of 30 kg/min. The velocity at the inlet is 1.5 m/s and that at the outlet is 14.5 m/s. Disregard the weight of the hose and water. Taking the momentum-flux correction factor to be 1.04 at both the inlet and the outlet, the anchoring force required to hold the hose in place is

- (a) 2.8 N      (b) 8.6 N      (c) 17.5 N      (d) 27.9 N      (e) 43.3 N

*Answer* (d) 27.9 N

**Solution** Solved by EES Software. Solutions can be verified by copying-and-pasting the following lines on a blank EES screen. (Similar problems and their solutions can be obtained easily by modifying numerical values).

```
m_dot=(30/60) [kg/s]
V1=1.5 [m/s]
V2=14.5 [m/s]
beta=1.04
rho=1000 [kg/m^3]
g=9.81 [m/s^2]
A1=m_dot/(rho*V1)
P_1_gage=rho*(V2^2-V1^2)/2
A1=pi*D^2/4
F+P_1_gage*A1=m_dot*beta*(V2-V1)
```

## 6-102

Consider water flow through a horizontal, short garden hose at a rate of 30 kg/min. The velocity at the inlet is 1.5 m/s and that at the outlet is 11.5 m/s. The hose makes a 180° turn before the water is discharged. Disregard the weight of the hose and water. Taking the momentum-flux correction factor to be 1.04 at both the inlet and the outlet, the anchoring force required to hold the hose in place is

- (a) 7.6 N      (b) 28.4 N      (c) 16.6 N      (d) 34.1 N      (e) 11.9 N

*Answer* (b) 28.4 N

**Solution** Solved by EES Software. Solutions can be verified by copying-and-pasting the following lines on a blank EES screen. (Similar problems and their solutions can be obtained easily by modifying numerical values).

```
m_dot=(30/60) [kg/s]
V1=1.5 [m/s]
V2=-11.5 [m/s]
beta=1.04
rho=1000 [kg/m^3]
g=9.81 [m/s^2]
A1=m_dot/(rho*V1)
P_1_gage=rho*(V2^2-V1^2)/2
A1=pi*D^2/4
F+P_1_gage*A1=m_dot*beta*(V2-V1)
```

## 6-103

A water jet strikes a stationary vertical plate horizontally at a rate of 5 kg/s with a velocity of 35 km/h. Assume the water stream moves in the vertical direction after the strike. The force needed to prevent the plate from moving horizontally is

- (a) 15.5 N      (b) 26.3 N      (c) 19.7 N      (d) 34.2 N      (e) 48.6 N

*Answer* (e) 48.6 N

**Solution** Solved by EES Software. Solutions can be verified by copying-and-pasting the following lines on a blank EES screen. (Similar problems and their solutions can be obtained easily by modifying numerical values).

$m_{\dot{}}=5$  [kg/s]

$V1=35$  [km/h]\*Convert(km/h, m/s)

$F=m_{\dot{}}*V1$

## 6-104

Consider water flow through a horizontal, short garden hose at a rate of 40 kg/min. The velocity at the inlet is 1.5 m/s and that at the outlet is 16 m/s. The hose makes a 90° turn to a vertical direction before the water is discharged. Disregard the weight of the hose and water. Taking the momentum-flux correction factor to be 1.04 at both the inlet and the outlet, the reaction force in the vertical direction required to hold the hose in place is

- (a) 11.1 N      (b) 10.1 N      (c) 9.3 N      (d) 27.2 N      (e) 28.9 N

*Answer* (a) 11.1 N

**Solution** Solved by EES Software. Solutions can be verified by copying-and-pasting the following lines on a blank EES screen. (Similar problems and their solutions can be obtained easily by modifying numerical values).

$m_{\dot{}}=(40/60)$  [kg/s]

$V1=1.5$  [m/s]

$V2=16$  [m/s]

$\beta=1.04$

$F_{\text{vertical}}=m_{\dot{}}*\beta*V2$

## 6-105

Consider water flow through a horizontal, short pipe at a rate of 80 kg/min. The velocity at the inlet is 1.5 m/s and that at the outlet is 16.5 m/s. The pipe makes a 90° turn to a vertical direction before the water is discharged. Disregard the weight of the pipe and water. Taking the momentum-flux correction factor to be 1.04 at both the inlet and the outlet, the reaction force in the horizontal direction required to hold the pipe in place is

- (a) 73.7 N      (b) 97.1 N      (c) 99.2 N      (d) 122 N      (e) 153 N

*Answer* (d) 122 N

**Solution** Solved by EES Software. Solutions can be verified by copying-and-pasting the following lines on a blank EES screen. (Similar problems and their solutions can be obtained easily by modifying numerical values).

```
m_dot=(80/60) [kg/s]
V1=1.5 [m/s]
V2=16.5 [m/s]
theta_2=90 [degree]
beta=1.04
rho=1000 [kg/m^3]
g=9.81 [m/s^2]
A1=m_dot/(rho*V1)
P_1_gage=rho*(V2^2-V1^2)/2
A1=pi*D^2/4
F_horizontal+P_1_gage*A1=m_dot*beta*(V2*cos(theta_2)-V1)
```

## 6-106

A water jet strikes a stationary vertical plate vertically at a rate of 18 kg/s with a velocity of 24 m/s. The mass of the plate is 10 kg. Assume the water stream moves in the horizontal direction after the strike. The force needed to prevent the plate from moving vertically is

- (a) 192 N      (b) 240 N      (c) 334 N      (d) 432 N      (e) 530 N

*Answer* (c) 334 N

**Solution** Solved by EES Software. Solutions can be verified by copying-and-pasting the following lines on a blank EES screen. (Similar problems and their solutions can be obtained easily by modifying numerical values).

```
m_dot=18 [kg/s]
V1=24 [m/s]
m_plate=10 [kg]
g=9.81 [m/s^2]
F_vertical-m_plate*g=m_dot*(0-V1)
```

## 6-107

The velocity of wind at a wind turbine is measured to be 6 m/s. The blade span diameter is 24 m and the efficiency of the wind turbine is 29 percent. The density of air is  $1.22 \text{ kg/m}^3$ . The horizontal force exerted by the wind on the supporting mast of the wind turbine is

- (a) 2524 N      (b) 3127 N      (c) 3475 N      (d) 4138 N      (e) 4313 N

*Answer* (b) 3127 N

**Solution** Solved by EES Software. Solutions can be verified by copying-and-pasting the following lines on a blank EES screen. (Similar problems and their solutions can be obtained easily by modifying numerical values).

```
V1=6 [m/s]
D=24 [m]
eta_turbine=0.29
rho=1.22 [kg/m^3]
A=pi*D^2/4
m_dot=rho*A*V1
eta_turbine=1-KE_2/KE_1
KE_1=m_dot*V1^2/2
KE_2=m_dot*V2^2/2
F=m_dot*(V2-V1)
```

## 6-108

The velocity of wind at a wind turbine is measured to be 8 m/s. The blade span diameter is 12 m. The density of air is  $1.2 \text{ kg/m}^3$ . If the horizontal force exerted by the wind on the supporting mast of the wind turbine is 1620 N, the efficiency of the wind turbine is

- (a) 27.5%      (b) 31.7%      (c) 29.5%      (d) 35.1%      (e) 33.8%

*Answer* (e) 33.8%

**Solution** Solved by EES Software. Solutions can be verified by copying-and-pasting the following lines on a blank EES screen. (Similar problems and their solutions can be obtained easily by modifying numerical values).

```
V1=8 [m/s]
D=12 [m]
F=-1620 [N]
rho=1.2 [kg/m^3]
A=pi*D^2/4
m_dot=rho*A*V1
KE_1=m_dot*V1^2/2
F=m_dot*(V2-V1)
KE_2=m_dot*V2^2/2
eta_turbine=1-KE_2/KE_1
```

## 6-109

The shaft of a turbine rotates at a speed of 800 rpm. If the torque of the shaft is 350 N·m, the shaft power is

- (a) 112 kW      (b) 176 kW      (c) 293 kW      (d) 350 kW      (e) 405 kW

*Answer* (c) 293 kW

**Solution** Solved by EES Software. Solutions can be verified by copying-and-pasting the following lines on a blank EES screen. (Similar problems and their solutions can be obtained easily by modifying numerical values).

$$n_{\text{dot}}=(800/60) \text{ [1/s]}$$

$$M=3500 \text{ [N-m]}$$

$$W_{\text{dot\_shaft}}=2*\pi*n_{\text{dot}}*M$$

## 6-110

A 3-cm-diameter horizontal pipe attached to a surface makes a 90° turn to a vertical upward direction before the water is discharged at a velocity of 9 m/s. The horizontal section is 5-m-long and the vertical section is 4-m long. Neglecting the mass of the water contained in the pipe, the bending moment acting on the base of the pipe on the wall is

- (a) 286 N·m      (b) 229 N·m      (c) 207 N·m      (d) 175 N·m      (e) 124 N·m

*Answer* (a) 286 N·m

**Solution** Solved by EES Software. Solutions can be verified by copying-and-pasting the following lines on a blank EES screen. (Similar problems and their solutions can be obtained easily by modifying numerical values).

$$D=0.03 \text{ [m]}$$

$$V=9 \text{ [m/s]}$$

$$L_{\text{horizontal}}=5 \text{ [m]}$$

$$L_{\text{vertical}}=4 \text{ [m]}$$

$$\rho=1000 \text{ [kg/m}^3\text{]}$$

$$A=\pi*D^2/4$$

$$m_{\text{dot}}=\rho*A*V$$

$$r=L_{\text{horizontal}}$$

$$M=r*m_{\text{dot}}*V$$

## 6-111

A 3-cm-diameter horizontal pipe attached to a surface makes a  $90^\circ$  turn to a vertical upward direction before the water is discharged at a velocity of 6 m/s. The horizontal section is 5-m-long and the vertical section is 4-m long. Neglecting the mass of the pipe and considering the weight of the water contained in the pipe, the bending moment acting on the base of the pipe on the wall is

- (a) 11.9 N·m      (b) 46.7 N·m      (c) 127 N·m      (d) 104 N·m      (e) 74.8 N·m

Answer (e) 74.8 N·m

**Solution** Solved by EES Software. Solutions can be verified by copying-and-pasting the following lines on a blank EES screen. (Similar problems and their solutions can be obtained easily by modifying numerical values).

```

D=0.03 [m]
V=6 [m/s]
L_horizontal=5 [m]
L_vertical=4 [m]
rho=1000 [kg/m^3]
g=9.81 [m/s^2]
A=pi*D^2/4
m_dot=rho*A*V
Vol_horizontal=pi*D^2/4*L_horizontal
m_water_horizontal=rho*Vol_horizontal
W_horizontal=m_water_horizontal*g
Vol_vertical=pi*D^2/4*L_vertical
m_water_vertical=rho*Vol_vertical
W_vertical=m_water_vertical*g
r_horizontal=L_horizontal/2
r_vertical=L_horizontal+D/2
r=L_horizontal
M-r_horizontal*W_horizontal+r_vertical*W_vertical=r*m_dot*V

```

## 6-112

A large lawn sprinkler with four identical arms is to be converted into a turbine to generate electric power by attaching a generator to its rotating head. Water enters the sprinkler from the base along the axis of rotation at a rate of 15 kg/s and leaves the nozzles in the tangential direction at a velocity of 50 m/s relative to the rotating nozzle. The sprinkler rotates at a rate of 400 rpm in a horizontal plane. The normal distance between the axis of rotation and the center of each nozzle is 30 cm. Estimate the electric power produced.

- (a) 5430 W      (b) 6288 W      (c) 6634 W      (d) 7056 W      (e) 7875 W

Answer (d) 7056 W

**Solution** Solved by EES Software. Solutions can be verified by copying-and-pasting the following lines on a blank EES screen. (Similar problems and their solutions can be obtained easily by modifying numerical values).

```
m_dot=15 [kg/s]
V_jet_r=50 [m/s]
n_dot=(400/60) [1/s]
r=0.30 [m]
omega=2*pi*n_dot
V_nozzle=r*omega
V_jet=V_jet_r-V_nozzle
T_shaft=r*m_dot*V_jet
W_dot=2*pi*n_dot*T_shaft
```

## 6-113

Consider the impeller of a centrifugal pump with a rotational speed of 900 rpm and a flow rate of 95 kg/min. The impeller radii at the inlet and outlet are 7 cm and 16 cm, respectively. Assuming that the tangential fluid velocity is equal to the blade angular velocity both at the inlet and the exit, the power requirement of the pump is

- (a) 83 W      (b) 291 W      (c) 409 W      (d) 756 W      (e) 1125 W

Answer (b) 291 W

**Solution** Solved by EES Software. Solutions can be verified by copying-and-pasting the following lines on a blank EES screen. (Similar problems and their solutions can be obtained easily by modifying numerical values).

```
n_dot=(900/60) [1/s]
m_dot=(95/60) [kg/s]
r1=0.07 [m]
r2=0.16 [m]
omega=2*pi*n_dot
T_shaft=m_dot*omega*(r2^2-r1^2)
W_dot=2*pi*n_dot*T_shaft
```

**6-114**

Water enters the impeller of a centrifugal pump radially at a rate of 450 L/min when the shaft is rotating at 400 rpm. The tangential component of absolute velocity of water at the exit of the 70-cm outer diameter impeller is 55 m/s. The torque applied to the impeller is

- (a) 144 N·m      (b) 93.6 N·m      (c) 187 N·m      (d) 112 N·m      (e) 235 N·m

*Answer* (a) 144 N·m

**Solution** Solved by EES Software. Solutions can be verified by copying-and-pasting the following lines on a blank EES screen. (Similar problems and their solutions can be obtained easily by modifying numerical values).

```
V_dot=(0.450/60) [m^3/s]
n_dot=(40/60) [1/s]
D2=0.70 [m]
V_2_t=55 [m/s]
r2=D2/2
omega=2*pi*n_dot
rho=1000 [kg/m^3]
m_dot=rho*V_dot
T_shaft=m_dot*r2*V_2_t
```

---

**Design and Essay Problem**

---

**6-115**

**Solution** Students' essays and designs should be unique and will differ from each other.

---

